



ASPIRAZIONE ESTERNA EXTERNAL SUCTION ASPIRACIONES EXTERNAS

SETTORE | SECTOR | SECTOR



IL SOTTOVUOTO PROFESSIONALE ANCHE A CASA TUA!

Pensate per venire incontro alle esigenze del mercato domestico e delle piccole e medie attività del settore alimentare, le nostre macchine confezionatrici ad aspirazione esterna, si caratterizzano per compattezza, facilità di utilizzo e vuoto professionale. Suddivise in due diverse linee, ABS e INOX, sono particolarmente indicate per confezionare sottovuoto affettati, formaggi e verdure.

Per garantire il corretto funzionamento della macchina e la saldatura efficace del sacchetto sottovuoto, si consiglia l'utilizzo esclusivo di buste gofrate.

PROFESSIONAL VACUUM ALSO AT HOME!

Designed to meet the needs of domestic market and of small and medium businesses in the food industry, our external suction packaging machines are characterized by compactness, ease of use and professional vacuum. Divided into two different lines, ABS and INOX, they are particularly suitable for sliced meats, cheese and vegetables. We recommend the exclusive use of embossed bags to guarantee the correct operation of the machine and the effective sealing of the vacuum bag.

¡EL VACÍO PROFESIONAL TAMBIÉN EN TU CASA!

Nuestras envasadoras al vacío exterior, diseñadas para satisfacer las necesidades del mercado doméstico y de las pequeñas y medianas empresas del sector alimentario, se caracterizan por su compactidad, facilidad de uso y vacío profesional. Subdivididas en dos líneas diferentes, ABS e INOX, son particularmente adecuadas para envasar al vacío embutidos, quesos y verduras. Para garantizar el correcto funcionamiento de la máquina y la eficaz soldadura de la bolsa, recomendamos el uso exclusivo de bolsas gofradas para conservación y/o cocción.

PRODOTTI LIQUIDI

Tutti i prodotti liquidi, come sughii, marinature e salse, possono essere confezionati sottovuoto mediante l'utilizzo di macchine ad aspirazione esterna solo ed esclusivamente in contenitori esterni per alimenti.

Le confezionatrici ad aspirazione esterna non consentono il confezionamento efficace di prodotti liquidi mediante buste sottovuoto: l'aspirazione diretta dei liquidi dal sacchetto danneggia in modo permanente la pompa del vuoto. È importante precisare che tutti i cibi, siano essi solidi, liquidi, cotti e crudi devono essere freddi al momento del confezionamento sottovuoto.

LIQUID PRODUCTS

All liquid products, such as sauces, marinades and dressings, can be vacuum packed by using external suction machines only in external food containers. The external suction packaging machines do not allow an efficient packaging of liquids by vacuum bags: the direct suction of liquids from the bag permanently damages the vacuum pump.

It is important to clarify that all foods, whether solid, liquid, cooked or raw must be cold at the time of vacuum packaging.

PRODUCTOS LÍQUIDOS

Todos los productos líquidos, como jugos, adobos y salsas, pueden envasarse al vacío utilizando máquinas de aspiración externas solo y exclusivamente en recipientes externos para alimentos. Las envasadoras de aspiración externas no permiten un envasado eficiente de alimentos líquidos mediante bolsas de vacío: la aspiración directa de líquidos de la bolsa daña permanentemente la bomba de vacío. Es importante precisar que todos los alimentos, ya sean sólidos, líquidos, cocidos o crudos deben estar fríos en el momento del envasado al vacío.

BUSTE COMPATIBILI | COMPATIBLE BAGS | BOLSAS COMPATIBLES



BUSTE E ROTOLI GOFRATI
EMBOSSED BAGS AND ROLLS
BOLSAS Y ROLLOS GOFRADOS



BUSTE E ROTOLI GOFRATI COTTURA
EMBOSSED COOKING BAGS AND ROLLS
BOLSAS Y ROLLOS GOFRADOS PARA COCCIÓN

ASPIRAZIONE ESTERNA
EXTERNAL SUCTION
ASPIRACIONES EXTERNAS



Manuali/Automatich/Semiautomatich
Saldatura multilivello
Larghezza saldatura 3 mm
Vuoto in barattoli
Pompa ad alto vuoto

Manual/Automatic/Semi-automatic
Multilevel welding
3 mm sealing width
Vacuum in jars
High performance vacuum pump

Manual/Automático/Semiautomático
Soldadura multinivel
Ancho de sellado 3 mm
Vacío en tarros
Bomba de alto vacío



SPRINT

SMILE

DIVA

SILHOUETTE

OMNIA

	SPRINT	SMILE	DIVA	SILHOUETTE	OMNIA
Dimensioni macchina Machine dimensions Dimensiones máquina	380x180x110 h mm	380x180x110 h mm	380x180x110 h mm	380x180x110 h mm	380x310x145 h mm
Peso Weight Peso	3 kg	2,8 kg	3,2 kg	2,8 kg	4,6 kg
Voltaggio Voltage Voltaje	110 V-60 Hz ● 230 V-50 Hz	230 V-50 Hz	110 V-60 Hz ● 230 V-50 Hz	230 V-50 Hz	110 V-60 Hz ● 230 V-50 Hz
Consumo Power consumption Consumo	0,25 kW	0,25 kW	0,25 kW	0,25 kW	0,38 kW
Vuoto in barattoli Vacuum in jars Vacío en tarros	×	×	✓	✓	✓
Saldatura buste cottura Sealing of cooking bags Soldadura bolsas cocción	×	✓	×	✓	✓
Barra saldante Welding bar Barra de soldadura	330 mm	330 mm	330 mm	330 mm	330 mm
Vuoto finale Final vacuum Vacío final	250 mbar	250 mbar	250 mbar	250 mbar	250 mbar
Dimensioni imballo Packaging dimension Dimensiones embalaje	420x235x175 h mm	420x235x175 h mm	420x235x175 h mm	420x235x175 h mm	415x355x190 h mm

● Voltaggio speciale su richiesta

Special voltage on demand

Voltaje especial a petición

ASPIRAZIONE ESTERNA
EXTERNAL SUCTION
ASPIRACIONES EXTERNAS



SPRINT

DIVA

SPRINT

1	Pulsante di avvio vuoto	Vacuum start button	Botón de inicio vacío
2	Pulsante di saldatura	Sealing button	Botón de soldadura
3	Led vuoto in corso	Vacuum in progress Led	Led vacío en progreso
4	Led saldatura attiva	Sealing in progress Led	Led soldadura activa

DIVA

1	Pulsante di accensione e spegnimento	Power on and off button	Botón de encendido y apagado
2	Pulsante vuoto in contenitori	Vacuum in jars button	Botón para vacío en contenedores
3	Pulsante di saldatura	Sealing button	Botón de soldadura
4	Led macchina in funzione	Machine in operation Led	Led máquina en funcionamiento
5	Led di vuoto e saldatura attivi	Vacuum and sealing in progress Led	Led de vacío y soldadura activa

SILHOUETTE

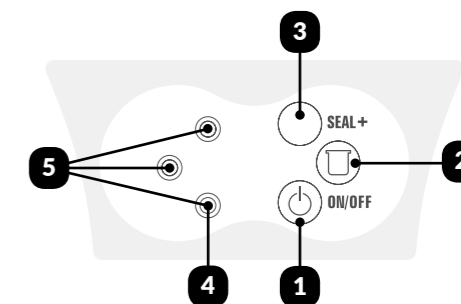
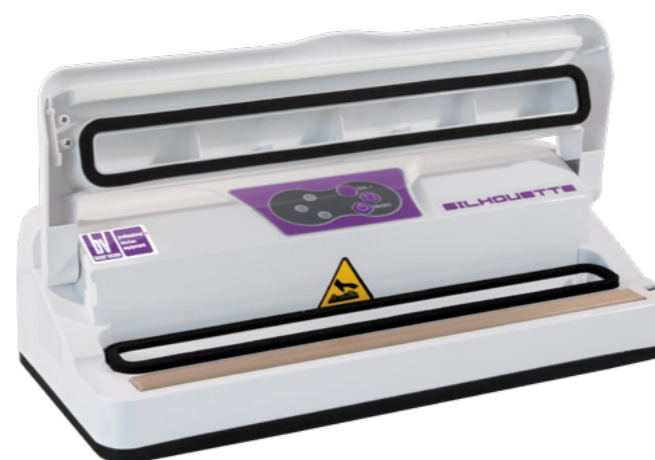
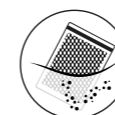

1	Pulsante di accensione e spegnimento	Power on and off button	Botón de encendido y apagado
2	Pulsante vuoto in contenitori	Vacuum in jars button	Botón para vacío en contenedores
3	Pulsante di saldatura busta cottura	Cooking bag sealing button	Botón de soldadura bolsas de cocción
4	Led macchina in funzione	Machine in operation Led	Led máquina en funcionamiento
5	Led di vuoto e saldatura attiva	Vacuum and sealing in progress Led	Led de vacío y soldadura activa

SMILE 

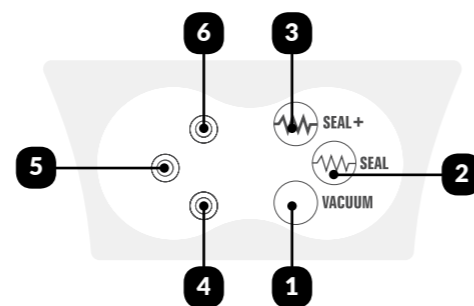

1	Pulsante di avvio vuoto	Power on and off button	Botón de inicio vacío
2	Pulsante di saldatura busta conservazione	Preservation bag sealing button	Botón de soldadura
3	Pulsante di saldatura busta cottura	Cooking bag sealing button	Botón de soldadura bolsas de cocción
4	Led vuoto in corso	Vacuum in progress Led	Led vacío en progreso
5	Led saldatura busta conservazione	Preservation bag sealing Led	Led soldadura bolsas conservación
6	Led saldatura busta cottura	Cooking bag sealing Led	Led soldadura bolsas cocción

OMNIA 

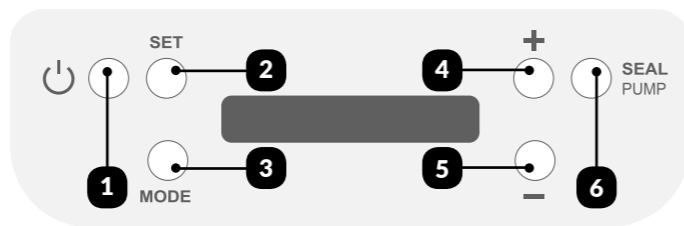

1	Pulsante di accensione e spegnimento	Power on and off button	Botón de encendido y apagado
2	Pulsante di selezione temperatura di saldatura	Sealing temperature selection button	Botón de selección de la temperatura de soldadura
3	Pulsante di selezione ciclo di vuoto	Vacuum cycles selection button	Botón de selección ciclo de vacío
4	Pulsante di incremento del tempo di saldatura	Increase sealing time button	Botón de aumento tiempo de soldadura
5	Pulsante di diminuzione del tempo di saldatura	Decrease sealing time button	Botón de disminución tiempo de soldadura
6	Pulsante saldatura anticipata / vuoto barattoli	Advanced sealing / vacuum in jars button	Botón de soldadura anticipada / vacío en tarros

BARATTOLI PER ASPIRAZIONE ESTERNA

Contenitori sottovuoto per alimenti, particolarmente adatti per il confezionamento di prodotti liquidi, si prestano anche alla conservazione di alimenti freschi e/o precotti. Trasparenti, completamente lavabili in lavastoviglie, sono comprensivi di coperchio con valvola e di cannucchia di aspirazione che, collegata alla macchina da un lato e al barattolo dall'altro, permette di estrarre perfettamente l'aria dal contenitore. Sono indicati per macchine ad aspirazione esterna dotate di ugello per l'aspirazione dell'aria dal barattolo. Si sconsiglia la messa in sottovuoto di alimenti caldi: tutti i prodotti vanno fatti raffreddare prima di procedere con le operazioni di confezionamento.

CONTAINERS FOR EXTERNAL SUCTIONS

These transparent and dishwasher-safe vacuum containers for food are particularly suitable for liquid and indicated for preservation of fresh and/or precooked food. They have a lid with a valve and a suction pipe that, connected to the machine on one side and to the jars on the other, allows the air to be perfectly extracted from the container. The containers are suitable for external suction machines which have a nozzle to extract air from the jar. We do not recommend hot food vacuum packaging: all products must be cooled before proceeding with the packaging operations.

RECIPIENTES PARA ASPIRACIÓN EXTERNA

Los recipientes de vacío para alimentos, especialmente indicados para envasar productos líquidos, también se prestan para la conservación de alimentos frescos y/o precocinados. Transparentes, completamente lavables en lavavajillas, incluyen una tapa con válvula y un tubo de aspiración que, conectado a la máquina por un lado y al recipiente por el otro, permite extraer el aire perfectamente del contenedor. Son adecuados para máquinas de aspiración externa equipadas con una boquilla para extraer el aire del recipiente. No se recomienda el envasado al vacío de alimentos calientes: todos los productos deben enfriarse antes de continuar con las operaciones de envasado.



Dimensioni mm / Dimensions mm / Dimensiones mm min 155x155x90 max 215x215x125

Capienza / Capacity / Capacidad min 600 ml max 2500 ml

Composizione / Composition / Composición Polypropylene

Refrigerazione / Refrigeration / Refrigeración ✓
 Congelazione / Freezer / Congelador ✓
 Microonde / Microwave / Microondas ✗

STRISCE ASSORBENTI*

Strisce assorbenti appositamente pensate per alimenti umidi, come carne e pesce, che durante la fase di confezionamento sottovuoto potrebbero sporcare la busta compromettendone la saldatura. Grazie alla composizione ad alto potere assorbente garantiscono il mantenimento del vuoto e una saldatura perfetta. Per un utilizzo efficace, si consiglia di posizionare la singola striscia assorbente al di sotto del punto in cui si andrà a saldare la busta.

ABSORBENT BANDS*

These absorbent bands are specially designed for wet food, such as meat and fish, which during the vacuum packaging phase could dirty the bag compromising the sealing. They guarantee vacuum retention and a perfect sealing thanks to their high absorbency composition. It is advisable to place the single absorbent band below the point where the bag will be sealed for an effective use.

TIRAS ABSORBENTES*

Tiras absorbentes especialmente diseñadas para alimentos húmedos, como carne y pescado, que durante la fase de envasado al vacío podrían ensuciar la bolsa y comprometer la soldadura. Gracias a la composición con alta absorbencia, garantizan el mantenimiento del vacío y una soldadura perfecta. Para un uso eficaz, aconsejamos colocar la tira absorbente debajo del punto donde se soldará la bolsa.



Dimensioni mm Dimensions mm Dimensiones mm	Pezzi/Confezione Pieces/Package Piezas/Paquete
180 x 50	30
230 x 50	30
280 x 50	30

*Si consiglia l'utilizzo con buste goffrate e macchine ad aspirazione esterna
 We recommend to use them with embossed bags and external suction machines
 Se recomienda el uso con bolsas gofradas y máquinas a aspiración externa

ASPIRAZIONE ESTERNA
EXTERNAL SUCTION
ASPIRACIONES EXTERNAS

INOX BASIC



ASPIRAZIONE ESTERNA
EXTERNAL SUCTION
ASPIRACIONES EXTERNAS

INOX BASIC



Automatiche
Saldatura multilivello
Larghezza saldatura 4 mm
Vuoto automatico
Vuoto in barattoli
Pompa ad alto vuoto



Automatic
Multilevel welding
4 mm welding width
Automatic vacuum
Vacuum in jars
High performance vacuum pump



Automáticas
Soldadura multinivel
Ancho de sellado 3 mm
Vacío automático
Vacío en tarros
Bomba de alto vacío



FRESH 33



FRESH 43



FRESH 53

Dimensioni macchina Machine dimensions Dimensiones máquina	385x300x170 h mm	470x305x180 h mm	590x290x180 h mm
Peso Weight Peso	6 kg	8 kg	12 kg
Voltaggio Voltage Voltaje	110 V-60 Hz ● 230 V-50 Hz	110 V-60 Hz ● 230 V-50 Hz	110 V-60 Hz ● 230 V-50 Hz
Consumo Power consumption Consumo	0,38 kW	0,45 kW	0,85 kW
Vuoto in barattoli Vacuum in jars Vacío en tarros	✓	✓	✓
Saldatura buste cottura Sealing of cooking bags Soldadura bolsas cocción	✓	✓	✓
Pompa Pump Bomba	13 l/min	21 l/min	26 l/min
Vuoto finale Final vacuum Vacío final	250 mbar	250 mbar	250 mbar
Barra saldante Welding bar Barra de soldadura	330 mm	430 mm	530 mm
Dimensioni imballo Packaging dimension Dimensiones embalaje	420x365x160 h mm	605x330x280 h mm	690x370x320 h mm

● Voltaggio speciale su richiesta

Special voltage on demand

Voltaje especial a petición

FRESH 33

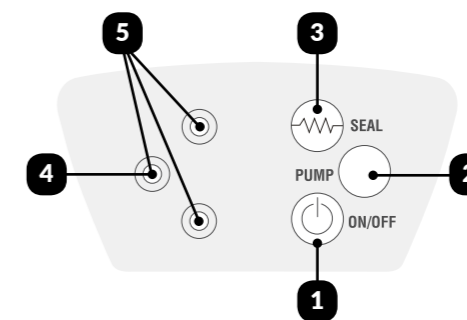

- | | | | |
|----------|--------------------------------------|------------------------------------|---------------------------------|
| 1 | Pulsante di accensione e spegnimento | Power on and off button | Botón de encendido y apagado |
| 2 | Pulsante vuoto in contenitori | Vacuum in jars button | Botón de vacío en contenedores |
| 3 | Pulsante di saldatura | Sealing button | Botón de soldadura |
| 4 | Led macchina in funzione | Machine in operation Led | Led máquina en funcionamiento |
| 5 | Led di vuoto e saldatura attivi | Vacuum and sealing in progress Led | Led de vacío y soldadura activa |

ASPIRAZIONE ESTERNA
EXTERNAL SUCTION
ASPIRACIONES EXTERNAS

INOX TOP



ASPIRAZIONE ESTERNA
EXTERNAL SUCTION
ASPIRACIONES EXTERNAS

INOX TOP



Automatiche/Semiautomatiche
Display in 5 lingue
Doppia saldatura
Larghezza saldatura 3 mm
Saldatura buste cottura
Vuotometro settoriale
Vuoto in barattoli
Pompe ad alto vuoto



Automatic/Semiautomatic
Display in 5 languages
Double sealing
3 mm welding width
Sealing of cooking bags
Sector vacuum gauge
Vacuum in jars
High performance vacuum pumps



Automático/Semiautomático
Display en 5 idiomas
Doble barra de sellado
Ancho de sellado 3 mm
Soldadura bolsas de cocción
Vacuómetro sectorial
Vacío en tarros
Bombas de alto vacío



MINI



MIDI



MAXI

Dimensioni macchina Machine dimensions Dimensiones máquina	420x290x165 h mm	515x290x180 h mm	620x290x195 h mm
Peso Weight Peso	6,5 kg	10 kg	13,5 kg
Voltaggio Voltage Voltaje	110 V-60 Hz ● 230 V-50 Hz	110 V-60 Hz ● 230 V-50 Hz	110 V-60 Hz ● 230 V-50/60 Hz
Consumo Power consumption Consumo	0,38 kW	0,55 kW	0,75 kW
Vuoto in barattoli Vacuum in jars Vacío en tarros	✓	✓	✓
Saldatura buste cottura Sealing of cooking bags Soldadura bolsas cocción	✓	✓	✓
Pompa Pump Bomba	19 l/min	26 l/min	30 l/min
Vuoto finale Final vacuum Vacío final	250 mbar	250 mbar	250 mbar
Barra saldante Welding bar Barra de soldadura	330 mm	(2x) ● 430 mm	(2x) ● 530 mm
Dimensioni imballo Packaging dimension Dimensiones embalaje	510x340x260 h mm	605x330x280 h mm	690x370x320 h mm

● Voltaggio speciale su richiesta
● Doppia saldatura

Special voltage on demand
Double sealing bar

Voltaje especial a petición
Barra con doble soldadura

MIDI

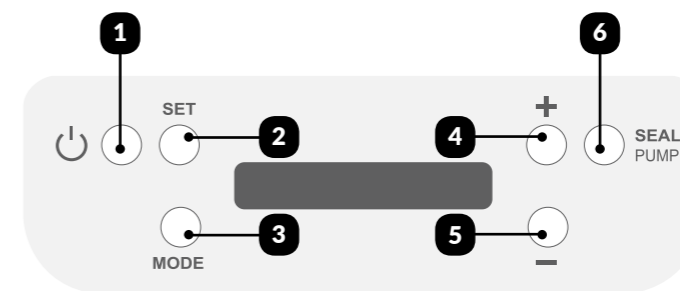

1	Pulsante di accensione e spegnimento	Power on and off button	Botón de encendido y apagado
2	Pulsante di selezione temperatura di saldatura	Sealing temperature selection button	Botón de selección de la temperatura de soldadura
3	Pulsante di selezione ciclo di vuoto	Vacuum cycles selection button	Botón de selección ciclos de vacío
4	Pulsante di incremento del tempo di saldatura	Increase time sealing button	Botón de aumento tiempo de soldadura
5	Pulsante di diminuzione del tempo di saldatura	Decrease time sealing button	Botón de disminución tiempo de soldadura
6	Pulsante saldatura anticipata / vuoto barattoli	Advanced sealing / vacuum in jars button	Botón de soldadura anticipada / vacío en tarros