

# SP 020 P

<b>MODEL</b> <b>SPIDOGLOSS SP020P</b>	<ul style="list-style-type: none"> <li>• <b>Black smooth surfaces</b></li> </ul>	<ul style="list-style-type: none"> <li>• <b>Max. temperature 400°C</b></li> </ul>
	<ul style="list-style-type: none"> <li>• <b>Manual Control</b></li> </ul>	<ul style="list-style-type: none"> <li>• <b>Glass ceramic</b></li> </ul>



## DESCRIPTION

Professional Contact Cooking System with Glass Ceramic plates, suitable for cooking a wide array of different foods, as such: toast, sandwich, meat, fish, vegetables, eggs, etc. High quality cooking result thanks to heat distribution uniformity and use of shock resistance, non-stick, non-porous and impermeable to smells and tastes Glass Ceramic Cooking Surfaces.

High versatility of use thanks to **SHB™ Plus** technology which allows combined heating (contact + infrared) and high cooking Temperature setting.

Up to 60% saving in Preheating Time thanks to **SHB™ Plus**. Up to 60% saving in Energy consumption thanks to the **Protek.Safe™** high efficiency insulation system which eliminates unnecessary energy loss.

## STANDARD COOKING FEATURES

### SETTINGS:

- Manual Control
- Temperature set: 120 °C – 400 °C.

## STANDARD TECHNICAL FEATURES

- **Double Black Smooth Glass Ceramic cooking plate:**  
2 250x250 mm.
- Stainless Steel Case
- Ergonomic Handle
- Self-locking Handle Bracket
- 4 Non-Slip Feets
- Removable Dip Tray
- ON/OFF button and LED light

## ACCESSORIES

- **METAL SCRAPER**  
Metallic scraper for Glass Ceramic Surfaces (included)
- **SPIDO CLEAN SPRAY DETERGENT**  
750 ml Spray Detergent for Glass Ceramic and Steel Surfaces (to be purchased separately)



# SP 020 P

Views  
Connection positions  
Dimensions and Weights  
Installation requirements  
Power supply

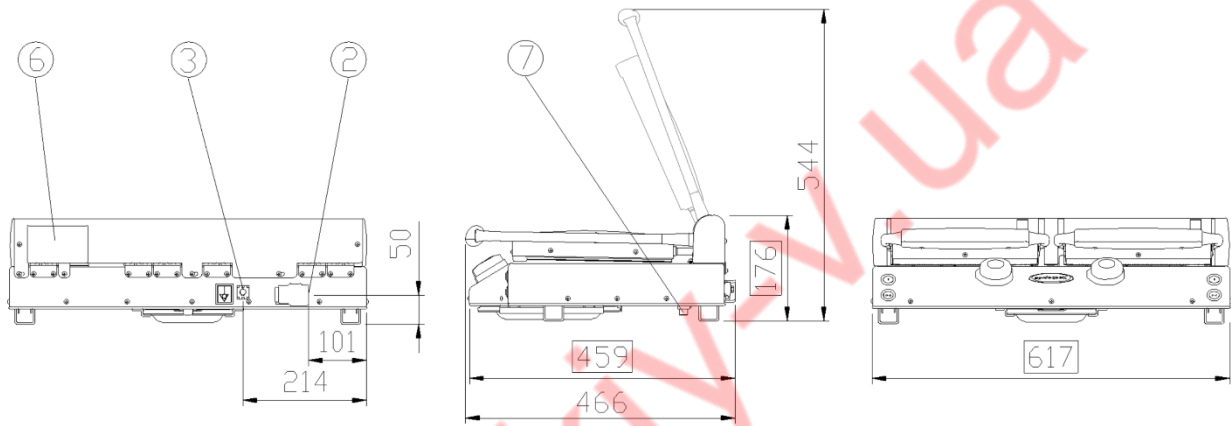

### CONNECTION POSITIONS

2	Terminal board power supply
3	Unipotential terminal
6	Technical data plate
7	Safety thermostat

### INSTALLATION REQUIREMENTS

Installations must conform to all local electrical systems, specifically minimum wire gauge required for field connection, hydraulic and ventilation codes.

### DIMENSIONS AND WEIGHT

Width	617 mm
Depth	459 mm
Height	176 mm
Net Weight	17 Kg

### POWER SUPPLY

	STANDARD
Voltage	230 V
Phase	1PH+N+PE
Cycle	50-60 Hz
Power	3 kW
Maximum Amp Draw	13 A
Power cable requirement	H07RN-F 3G 1.5 mm <sup>2</sup>
Cord diameter	10 mm
Plug	SCHUKO

# SP 020 P

Wiring diagrams

SP 020 P

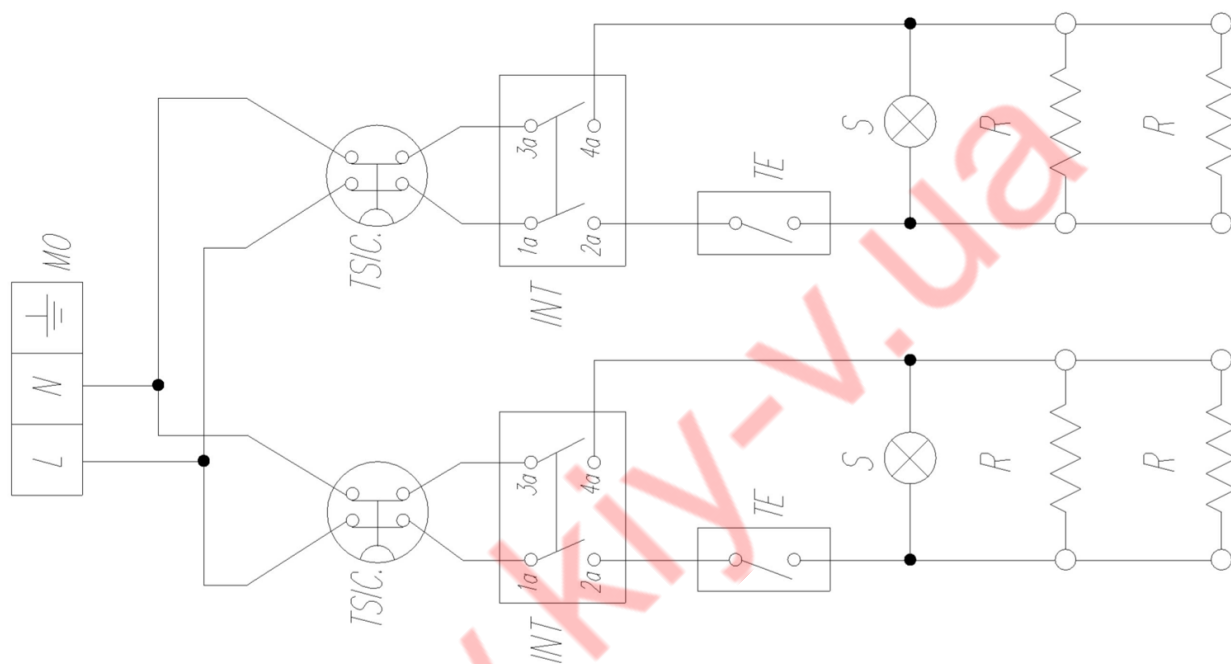

### WIRING DIAGRAMS

INT	Switch
MO	Terminal board
R	Heating element
S	Pilot light
TE	Thermostat
TS	Safety thermostat