



spidocook 596040 SpidoGlass Double Ceramic Contact Grill Instruction Manual

[Home](#) » [Spidocook](#) » spidocook 596040 SpidoGlass Double Ceramic Contact Grill Instruction Manual 

Contents

- 1 spidocook 596040 SpidoGlass Double Ceramic Contact Grill
- 2 Introduction
- 3 Safety regulations
- 4 Safety regulations for use
- 5 Transporting and unpacking
- 6 Getting started
- 7 Positioning
- 8 Electrical connections
 - 8.1 INSTRUCTIONS FOR THE USER
- 9 General appliance operating instructions
- 10 Manual control operation
 - 10.1 SpidoTouch digital control operation
 - 10.2 Time and cooking temperature parameter setting
- 11 Routine maintenance
- 12 Inactivity
- 13 Disposal at end of life
- 14 After-sales assistance
- 15 Certification
- 16 Guarantee
- 17 Documents / Resources
 - 17.1 References
- 18 Related Posts

spidocookTM

spidocook 596040 SpidoGlass Double Ceramic Contact Grill



Introduction

Dear Customer,

We would like to congratulate and thank you for choosing to purchase an appliance in the SPIDOGLOSS range by SpidoCook.; we hope this is just the beginning of a fruitful and long-lasting partnership. As you are aware, the SPIDOGLOSS range of grills, are equipped with the SHB system for contact and infra-red cooking, and ultra-rapid and uniform heating hobs. The contact grills of the SPIDOGLOSS are available in the manual and digital version with the innovative SpidoTouch control.\

Dealer:

Installer:

Installation date:

Safety regulations

Safety regulations for installation and maintenance

- Read this guide carefully before installing or maintaining the appliance, and conserve this guide with care for any future consultation of users.
- All installation, assembly and non-routine maintenance operations must be performed exclusively by qualified technicians that are authorised by Spidocook S.r.l., in compliance with the regulations in force in the user country and with respect to the regulations on systems and work safety.
- Disconnect the oven from its electrical mains supplies before installation or maintenance.
- Check that systems are compliant to the installation country standards and to the specifications indicated on the appliance rating plate before installing the appliance.
- Interventions, alterations or modifications not expressly authorized that do not comply with the indications in this manual shall invalid-date the guarantee.
- Installation or maintenance that fails to respect the indications in this manual may cause damage, injury or fatal accidents.

- Given its potential danger, the package material must be kept out of reach of children or animals, and properly disposed of as called for by local regulation.
- The ratings plate provides essential technical information that is of utmost importance for any appliance maintenance or repairs. Do not remove, damage or modify the plate.
- Failure to follow these regulations may cause damage or (fatal) in-jury, subsequently invalidating the guarantee and relieving Spidocook S. r.l. of all liability.
- The parts protected by the manufacturer or his agent shall not be adjusted by the installer.

Safety regulations for use

- Read this guide carefully before using the appliance or performing routine maintenance, and conserve this guide with care for any future consultation of users.
- Following procedures other than those indicated in this guide to use and clean the appliances is considered inappropriate and may cause damage, injury or fatal accidents; in addition to invalidating the guarantee and relieving Spidocook S.r.l. of all liability.
- The cooking surfaces are not to be used for storage.
- The appliance shall not be cleaned with a water jet.
- The appliance or part of appliance are not to be immersed.
- **WARNING:** If Surface is cracked, immediately disconnect the appliance or appropriate part of the appliance from the supply.
- This appliance can be used by children aged from 8 years and above and persons with reduced physical, sensory or mental capabilities or lack of experience and knowledge if they have been given supervision or instruction concerning use of the appliance in a safe way and understand the hazard involved. Children shall not play with the appliance. Cleaning and user maintenance shall not be made by children without supervision.
- Children must be supervised to ensure they do not play with the appliance.
- This appliance can only be used for cooking food in industrial and professional kitchens upon completion of scheduled training courses; all other uses are not compliant to the scope of use and therefore hazardous. In particular, the appliance can be used for:
 - Cooking food on the grill;
 - Grill meat, fish and vegetables;
 - Toasts, Sandwiches and Focaccia.
- Monitor the appliance during its entire operation cycle.
- If the appliance does not function or if there are any functional or structural alterations, disconnect the electricity and contact an Spidocook S.r.l. authorised customer service agent. Do not attempt to independently repair the appliance. Request Spidocook S.r.l. original spare parts for any repairs necessary. Failure to observe these regulations may cause damage or (fatal) injuries, and also invalidates the guarantee.
- To ensure that the appliance is in perfect use and in a safe condition, maintenance and inspections should be performed yearly by an authorised customer service agent.
- Do not use the contact grills SPIDOGLOSS to heat pots or pans
- Should not be placed on the glass ceramic surfaces aluminum foil or plastic containers.
- Do not install the appliance near flammable materials.
- Do not use foods containing highly flammable ingredients (e.g. alcohol-based foods). Substances with a low

flammability point may burst into flames and therefore constitute a fire.

- If the appliance is placed on a support structure on wheels, make sure that any movement will not damage electrical wiring or any other components.

RISK OF BURNS and INJURY!

Pay high attention while the contact grill is working as it gets very hot, can cause severe skin burns. In case of burns immediately cool down the burned part with cold running water and seek medical advice. To prevent accidents and to avoid damaging the appliance, all personnel should be informed as to normal safety procedures and given the necessary training.

RISK OF FIRE!

- When using the appliance for the first time, make sure over the cooking surface of the contact grill SPIDOGLOSS there are no instruction manuals, plastic bags or accessories.
- Before to turn on the contact grill for the first time, insert the fat collection drawer. Then you need to clean the glass ceramic surfaces with a damp cloth and a mild detergent to remove grease industrial protective which is deposited on the surface during manufacture.
- Once it dries, turn the power on and let the appliance run for at least an hour at the maximum temperature. Presence of smoke and odors are considered transient phenomena due to the degradation of industrial oils in the stainless steel parts. This phenomenon will be no longer present for successive starting of the appliance.
- Do not place sources of heat (i.e. grills, fryers, etc.), highly flammable substances or fuels in the vicinity of the appliance (i.e. gasoline, petrol, bottles of alcohol, etc...).
- Do not use highly flammable food or liquids while cooking (ex. alcohol).

RISK OR ELECTRICAL SHOCK

Do not open the compartments marked with these symbols: access is reserved to qualified installer authorised by Spidocook S.r.l. Failure to observe this regulation invalidates the guarantee and may cause damage or (fatal) injuries.

Explanation of pictograms

Danger! Situation presenting immediate danger, or a hazardous situation which could cause injury or death.

- Danger: fire hazard!
- Danger: electric shock!
- Read operator's manual
- Danger: risk of burns
- Tips and useful information
- Protective earth symbol
- Equipotentially symbol
- Consult other chapter

Before installing the appliance carefully read chapter "Safety regulations" (page 3). During installation, wear appropriate protective clothing (protective footwear, gloves, etc.).

Transporting and unpacking

- Make sure that the appliance is not in danger of tip-ping over during transportation. Check the package on receipt for any visible damage. If damage is found, immediatly contact Spidocook S.r.l. and DO NOT in-stall the appliance.
- The packaging materials, given their po-tential danger, must be kept out of reach of children and animals, and correctly
- disposed of in compliance with local regulations. Spidocook S.r.l. has followed the NON-STOP EF-FORTS philosophy to increase the environmental compatibility of its products to reduce energy con-sumption and wastes.

Spidocook S.r.l. wishes to protect the environment and invites the consumer to dispose of waste in recycling bins.

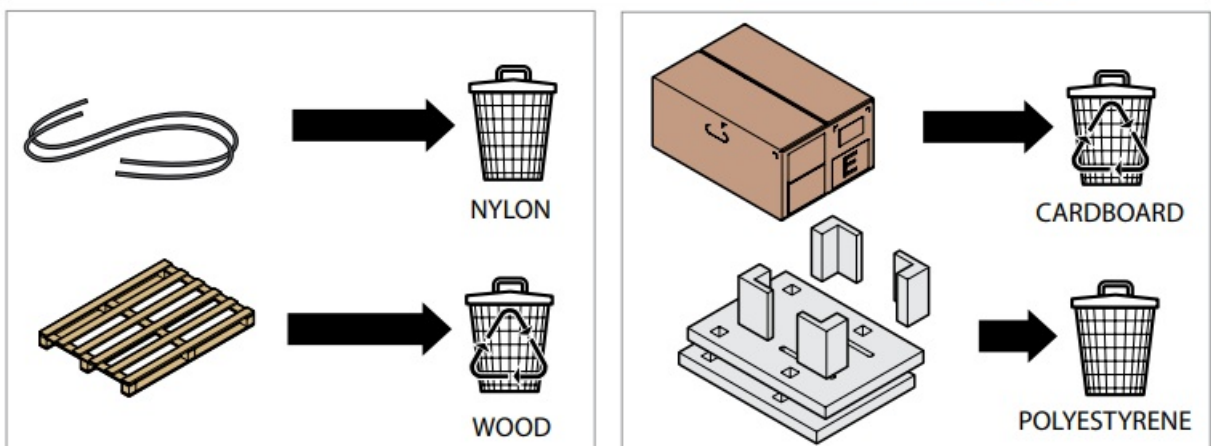
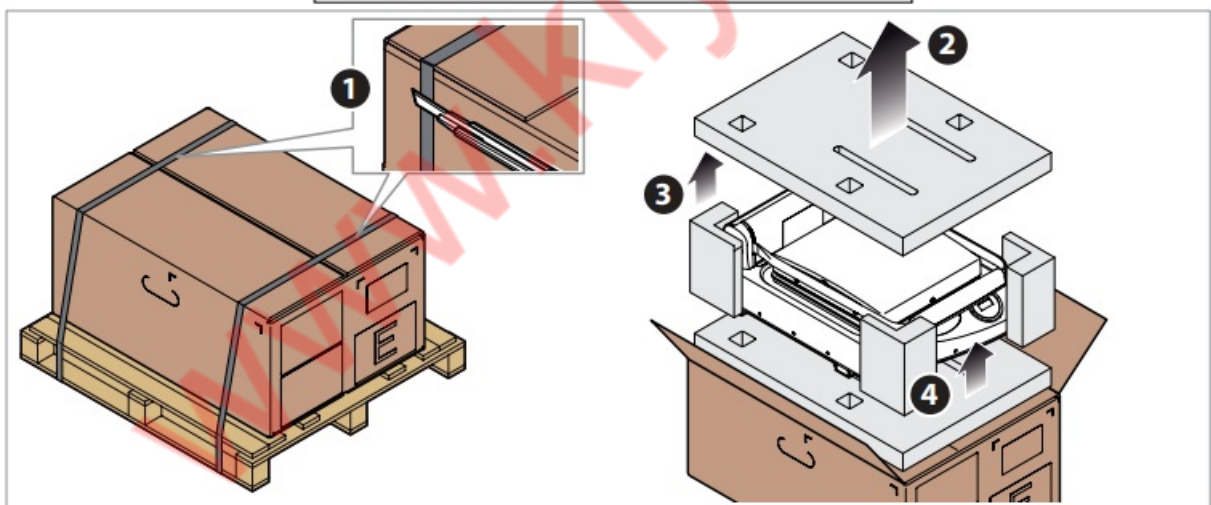
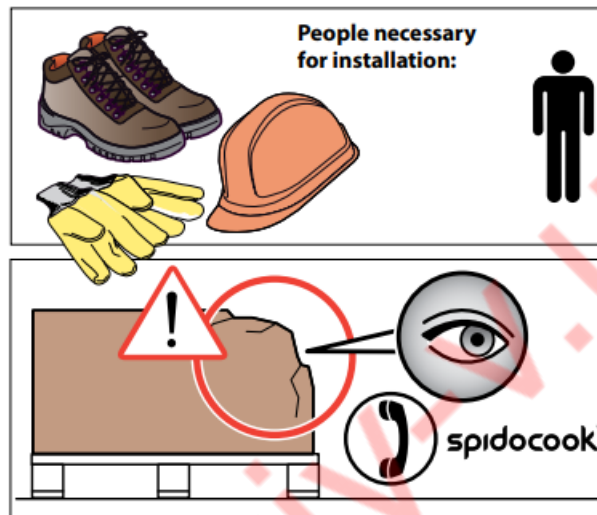

Getting started

Checking package contents

Before installing the appliance, check that the following packaged components are present and free of damage:

- SPIDOGLOSS grills
- technical documents (use and installation manual, “technical specifications” sheet);
- scraper;
- brass scourer.

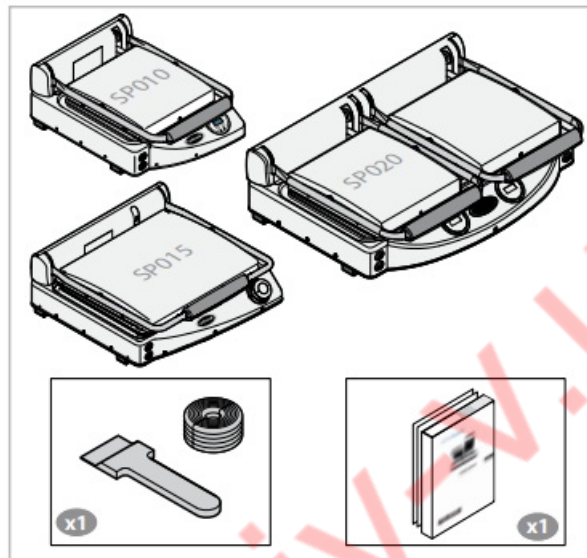

Removing the protective film

Slowly remove the protective films from the appliance: clean any glue residue with appropriate solvents without using tools, abrasive detergents or acids that could ruin the surfaces. The removed film, given its potential danger, must be kept out of reach of children and animals; and correctly disposed of in compliance with local regulations.

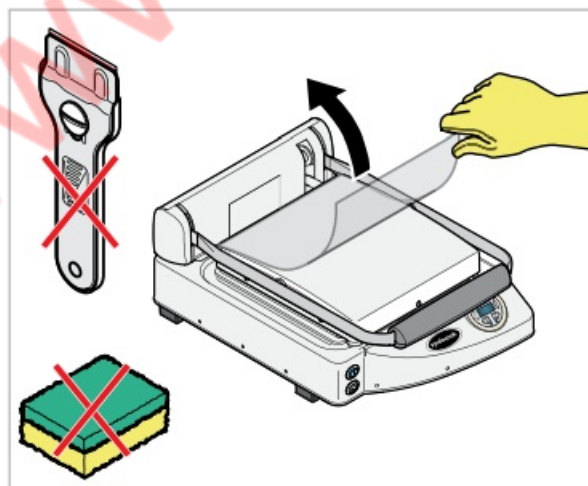

Fat collection drawer positioning

The supplied fat collection drawer to collect the liquid waste that is deposited on glass ceramic surfaces. The rounded drainage channel for the liquids, flowing all around the hobs, can easily convey liquids and dirt into the removable drawer to further facilitate the cleaning. Before to use for the first time the grill insert the-supplied fat collection drawer in the in the front seat as shown in the ‘image.

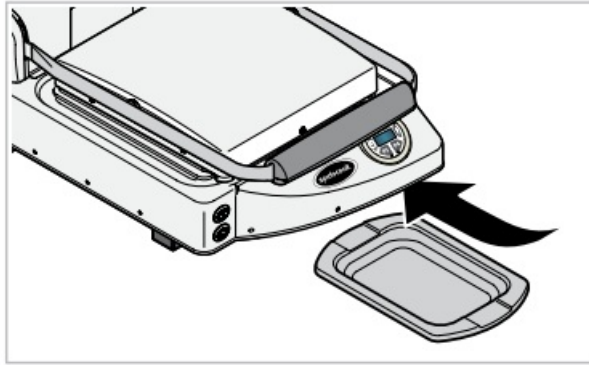

Positioning

Characteristics of the installation area

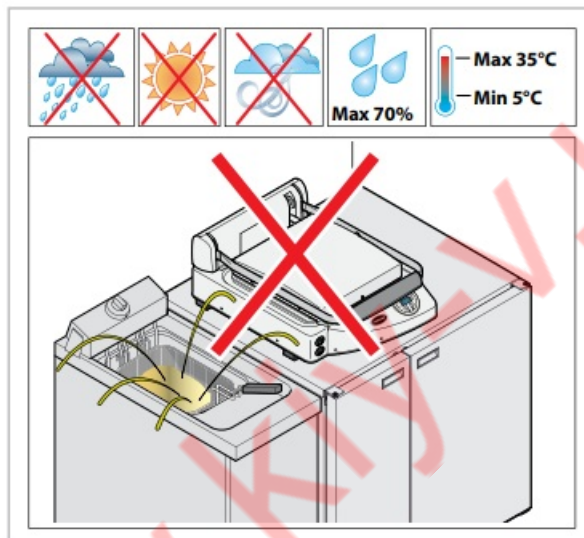

Install the appliance in areas:

- dedicated and conforming to the cooking of industrial foods;
- having adequate air ventilation;
- that comply with the local laws and recommendations;
- protected against the weather;
- with temperatures between +5° to +35°C maximum;
- having a maximum humidity of 70%.

Do not install the appliance near other appliances that reach high temperatures in order to avoid damaging electrical parts.

For additional technical information on the appliance, consult the “technical specifications” sheet attached to the appliance.

Models

Smooth black surfaces	MODELS	CONTROL	SIZE cooking surface (mm)	SIZE WxDxH mm	Electric power (kW)	Weight (kg)
	SP010P	manual	250×250	331 x 458 x 176	1,5	10
	SP010E	digital	250×250	331 x 458 x 176	1,5	10
	SP015	manual	400×300	481 x 457 x 182	2	14
	SP015P	manual	400×300	481 x 457 x 182	2,8	14
	SP020	manual	250×250 (x2)	619 x 458 x 176	2	17
	SP020P	manual	250×250 (x2)	619 x 458 x 176	3	17
	SP020E	digital	250×250 (x2)	619 x 458 x 176	3	17

Black furrowed upper surfaces	MODELS	CONTROL	SIZE cooking surface (mm)	SIZE WxDxH mm	Electric power (kW)	Weight (kg)
	SP010PR	manual	250×250	331 x 458 x 176	1,5	10
	SP010ER	digital	250×250	331 x 458 x 176	1,5	10
	SP015R	manual	400×300	481 x 457 x 182	2	14
	SP015PR	manual	400×300	481 x 457 x 182	2,8	14
	SP020R	manual	250×250 (x2)	619 x 458 x 176	2	17
	SP020PR	manual	250×250 (x2)	619 x 458 x 176	3	17
SP020ER	digital	250×250 (x2)	619 x 458 x 176	3	17	

Transparent smooth surfaces	MODELS	CONTROL	SIZE cooking surface (mm)	SIZE WxDxH mm	Electric power (kW)	Weight (kg)
	SP010PT	manual	250×250	331 x 458 x 176	1,5	10
	SP010ET	digital	250×250	331 x 458 x 176	1,5	10
	SP015T	manual	400×300	481 x 457 x 182	2	14
	SP015PT	manual	400×300	481 x 457 x 182	2,8	14
	SP020T	manual	250×250 (x2)	619 x 458 x 176	2	17
	SP020PT	manual	250×250 (x2)	619 x 458 x 176	3	17
SP020ET	digital	250×250 (x2)	619 x 458 x 176	3	17	

Appliance distances

Position the appliance respecting the indicated distances in the diagram and so that the back of the oven is easily accessible for appliance connections and maintenance.

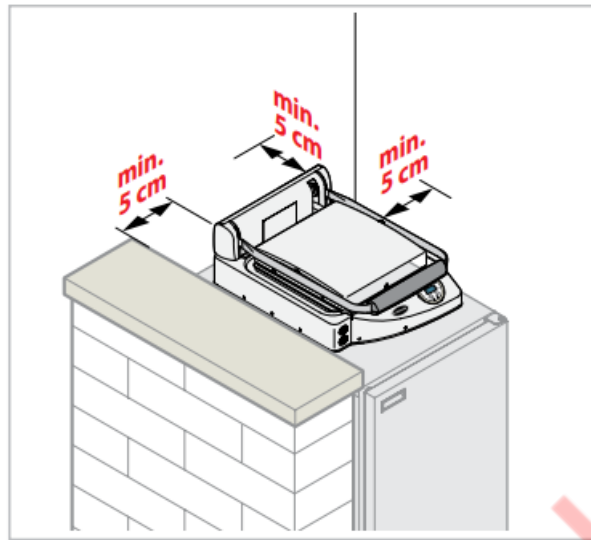

Do not install the appliance near inflammable or heat sensitive materials, walls or furniture. Otherwise, protect them with appropriate non inflammable materials in compliance with fire prevention regulations.

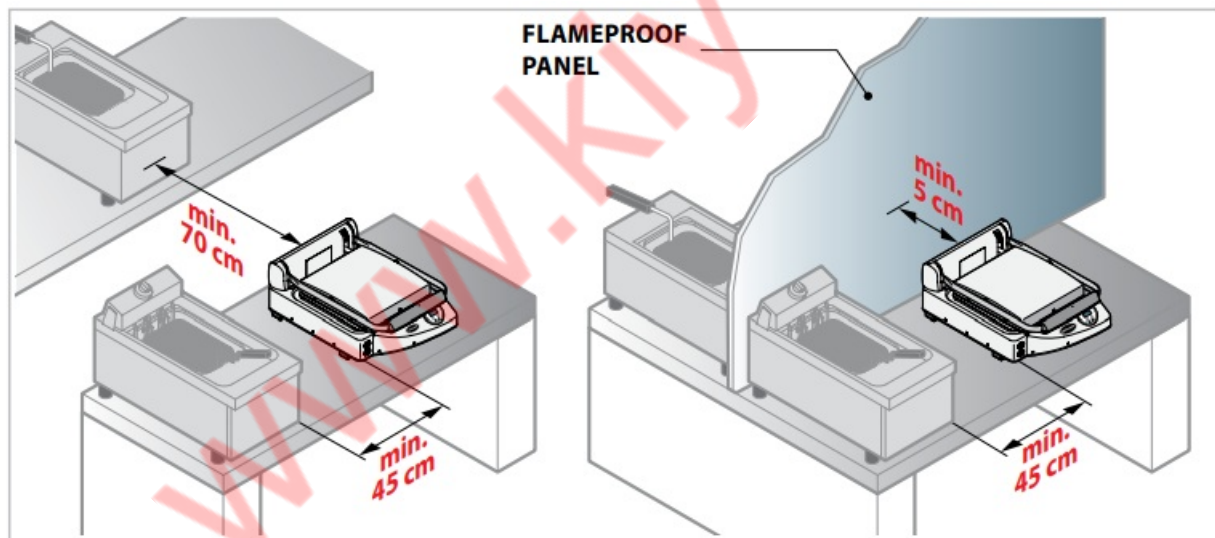

Electrical connections

- Before installing the appliance carefully read chapter "Safety regulations" (page 3).
- Connections to the main power and the electrical system must comply with the regulations in force in the country of installation of the appliance; and all connections must be performed by qualified in-staller authorised by Spidocook S.r.l. Failure to comply with these regulations may cause damage and injuries, invalidates the guarantee and relieves Spidocook S.r.l. of all liabilities.
- Before connecting the appliance to the mains electricity, always compare the power supply data with that of the appliance specified on the rating plate.
- The appliance must be positioned so that the power plug is accessible (for appliances fitted with Schuko plugs).

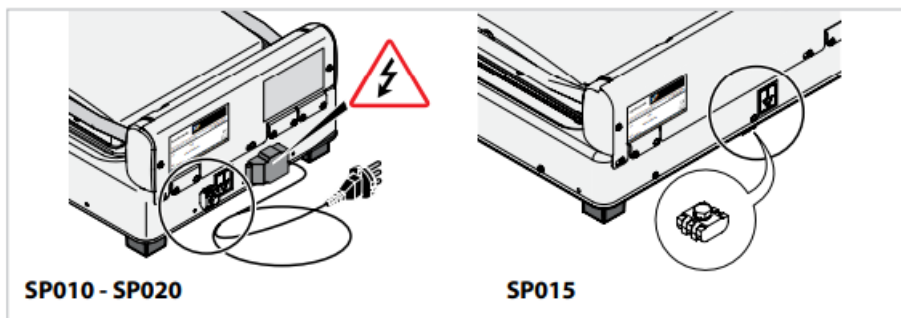

Checks

- The copper jumper and the electrical cable must be secured together beneath the screw in its tightening direction; and the electrical connections must be well secured before connecting the appliance to the mains electricity.
- check for any electrical dispersion between the phases and the ground, and for electrical continuity between the external casing and the main ground line.
- Check that the power supply voltage does not deviate from the nominal voltage value specified on the appliance rating plate when the appliance is operating.

Replacing the power supply cable

The cable must be replaced by UNOX or by its technical assistance service, and in all cases by a person with similar qualification in order to avoid possible risks.

Follow the procedures below to replace the power supply cable:

- open the terminal board cover;
- remove the cable by disconnecting it from the terminal board;
- consult the “Technical Specifications” sheet (Power supply-Connection Diagram): the sheet indicates all possible wiring diagrams and the specifications that the new cable must have in reference to the wiring selected (Cable Type);
- secure the new cable using the cable clamp;
- Close the terminal board cover.

INSTRUCTIONS FOR THE USER

Before using the appliance:

- make sure that you have a system conformity and use permit certificate that is issued by a Spidocook S.r.l. authorised installer;
- carefully read chapter “Safety regulations” (page 3).

General appliance operating instructions

- Thoroughly clean the appliance when using it for the first time (refer to the “Routine maintenance” section on page 18); let it run without food on the plate and at the maximum temperature for approximately 1 hour in order

to eliminate any unpleasant odours caused by the protective grease used in the factory. This phenomenon will be no longer present for successive starting of the appliance.

- Operate the SPIDOGLOSS at a room temperature between +5 °C e +35 °C (41 e 95 °F).
- Do not use the contact grills SPIDOGLOSS to heat pots or pans.
- Should not be placed on the glass ceramic surfaces aluminum foil or plastic containers.



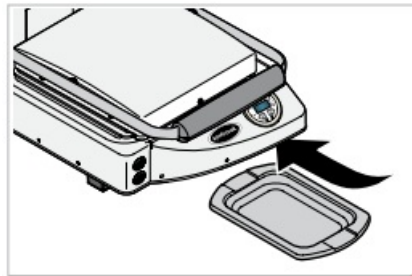

RISK OF BURNS and INJURY!

Pay high attention while the contact grill is working as it gets very hot, can cause severe skin burns. In case of burns immediately cool down the burned part with cold running water and seek medical advice To prevent accidents and to avoid damaging the appliance, all person-nel should be informed as to normal safety procedures and given the necessary training.

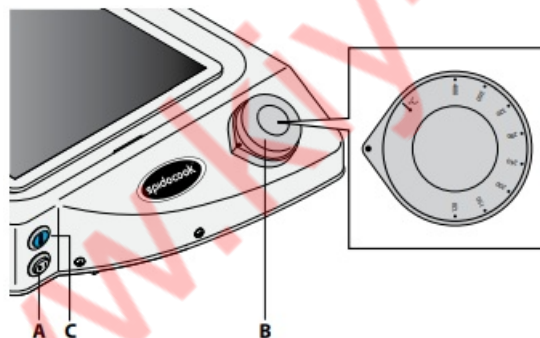

Manual control operation





- Control Panel:
 - Power switch (A)
Activates the unit.
 -  Button located outside: contact grill off
 -  Button located inside: contact grill on
 - Thermostat knob (B)
Rotate clockwise the thermostat knob and set the cooking temperature (from 80 to 400 C°).
 - Temperature light (C)
 -  Light on: Heat is on.
 -  Light off: Set temperature reached



SpidoTouch digital control operation

- Control Panel:
 - Power switch (A)

Activates the unit.





-  Button located outside: contact grill off
-  Button located inside: contact grill on
- SpidoTouch digital control (B)

Allows you to set the cooking time and temperature (from 80 to 350 C°) and store up to 4 programmes.

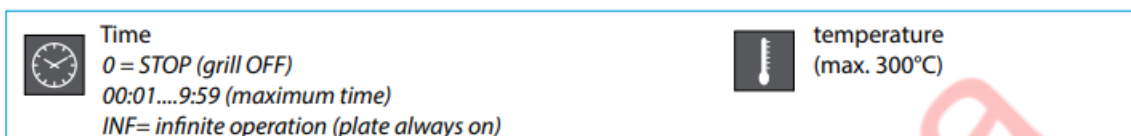
- Temperature light (C)
 -  Light on: Heat is on.
 -  Light off: Set temperature reached

Time and cooking temperature parameter setting



- Set the cooking duration by repeatedly pushing (slow mode) or holding down (fast mode) the  button until the desired time appears on the screen (the value has been saved when the LED (D1) stops flashing).
- The countdown starts right after having set the duration with a value other than “0”, and the plate will start to heat until reaching the pre-set temperature of 200°C. To change this value, push the  button until the desired temperature appears on the screen (the value has been saved when the LED (D2) stops flashing).
NOTE: if you press the button before the duration LED (D1) has stopped flashing, the plate will heat until it reaches a temperature of approximately 200°C.
- To prematurely stop cooking, repeatedly press the  button until 00:00 appears on the screen.
- Example: If you want to cook at a temperature of 220°C for 5 minutes and 30 seconds.
 - Turn on the plate with the button (A), hold down the  button until 5.30 (5 minutes and 30 seconds) appears on the screen. After a few seconds, the LED (D1) stops flashing: the cooking time has been saved, the countdown starts and the plate starts to heat to the pre-set temperature of 200°C.
 - To increase the temperature, hold down the button  until the temperature of 220°C appears on the screen. After a few seconds, the LED (D2) stops flashing: the cooking temperature has been saved. When the pilot light (C) turns off, the plate has reached the set temperature (220°C).

• Program storage and use

Up to four programmes (P1, P2, P3 and P4) can be saved for subsequent use.

• PROGRAM STORAGE

- Set the time and temperature parameters as describe previously (example 8 min. / 220°C).
- To store the program press and hold the button P1, P2, P3 or P4 (ex. P3) for at least 3 seconds: the confirmation of recording takes place with the light on for one second of the LED light (D3) and the buzzer.
- E.g.: Programme P3 = the plate will work at 220°C for 8 minutes

• USING A PROGRAMME

To start one of four programs from the state “STOP” (0- grill OFF) or “INFINITY” (INF – plate continuously on) push P1, P2, P3 or P4.

- At the end of the program will be restored the initial state (STOP o INFINITY).
- In case the user start a program the cooking time can be stopped press the key  by taking the time to zero or by pushing the button of the program in use.

• **Oven-user communication (only for models with digital control)**

The digital control panel SpidoTouch used in SPIDOGLASS digital grills is designed to alert the user to possible error messages or failure.

If there is any warning or allarms push the button “P4” to slide them.

• **Warning messages:**

When a malfunction is detected which allows the appliance to continue operating, albeit in a limited manner, a WARNING message is displayed. The device continues to run and the WARNING message remains on the display until any operation button is pressed.

DISPLAY MESSAGE	Description	Effect	Problem solution
W01	The temperature of the appliance power P.C.B. is too high	The appliance continues to operate but there is a risk of permanent damage to the power P.C.	Contact the Customer Assistance Service
W02	The temperature of the appliance control board is too high	The appliance continues to operate but there is a risk of permanent damage to the control board	Contact the Customer Assistance Service
W10	Basic control board setting error	The appliance keeps on working (with some limitations due to the setting involved on the error)	Contact the Customer Assistance Service

• **Allarm messages:**

When a condition arises which prevents the appliance from operating at all, an ALARM signal is displayed and the appliance must be switched to its STOP status. The device stops operating and the ALARM message appears on the oven display until the problem is resolved. If the device is operating when the ALARM status occurs, it will shut down and the alert corresponding to the detected problem will be displayed. To resolve a problem of this type, contact an Authorised Assistance Centre. Once the problem has been resolved, the appliance can be reactivated by pressing the «START» button.

DISPLAY MESSAGE	Description	Effect	Problem solution
A01	Temperature probe alarm	Appliance shutdown	Contact the Customer Assistance Service
A03	The control board is no longer communicating with the power board	Appliance shutdown	Contact the Customer Assistance Service

- **Maintenance in case of failure:**

In case of failure, in case of failure, failure of the ceramic surface or in case of occurrence of cracks, immediately disconnect the unit from the mains and call a service center for replacement of glass.

Routine maintenance

Any routine maintenance procedure must be performed:

- after disconnecting the appliance from the power supplies;
- after having put on the proper personal protection equipment (i.e. gloves, etc...).

Clean the grill daily to maintain proper levels of hygiene. When cleaning any component or accessory NEVER use:

- abrasive or powder detergents;
- aggressive or corrosive detergents (i.e. hydrochloric/muriatic or sulphuric acid). Caution! Never use these substances also when cleaning the appliance substructure and floors;
- abrasive or sharp tools (i.e. abrasive sponges, scrapers, steel bristled brushes, etc...);
- **water sprays.**

When cleaning the appliance or its components, do not submerge them in water.

In case of cracks or damage to the surfaces of the ceramic glass plates disconnect the appliance from the mains (Standard: EN 60335-2-38:2003 + A1:2008).

External steel structures/drawing :

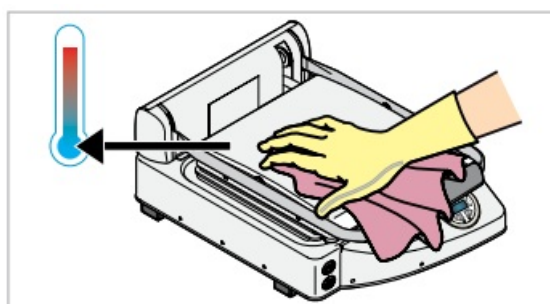

Wait for the surfaces to cool off.

Use only a soft cleaning cloth dampened with a little soap and water. Rinse and dry completely. As an alternative, only use detergents recommended by Spidocook S.r.l.; other products may cause damage thereby invalidating the guarantee. Read the instructions provided by the detergent producer for their use.

Glass ceramic contact grills:

The glass ceramic contact grills, even if very hot don't give the feeling of the actual heat, therefore, before cleaning them off, make sure they have completely cooled.

- Use only a soft cleaning cloth dampened with a little soap and water. Rinse and dry completely. Do not use acids, solvents and / or ammonia (alcohol, benzine, thinner, etc..) that could self-ignite when thrown on the grill when it is not completely cooled.
- For the cleaning of the appliance do not use any tools that might damage the glass ceramic, it is necessary to use the scraper with rounded edges of the blade that came with the grill.
- Use the scraper with caution and make sure the blade contact the plates very good. Do not use the edge of the scraper as this may cause scratches on the plate that would compromise the overall appearance and cleanability.
- Substitute the blade of the scraper whenever when it is no longer perfectly sharp.
- After using the scraper cover the blade with the special protection and do not leave the scraper unattended within the reach of children.
- **Collection of cooking waste:**
The cooking residues are channeled through the hole in the gutter directly in the dripping tray under the contact grill. Therefore proceed to empty the tray regularly to prevent internal overflows.

Inactivity

Follow the precautions below during inactivity:

- disconnect the power supplies to the appliance;
- we recommend rubbing a soft cloth lightly doused with mineral oil on all stainless steel surfaces.

At first reuse:

- clean the appliance and its accessories thoroughly (see chapter "Routine maintenance" at page 18);
- restore the power supplies to the appliance;
- inspect the appliance before using it;
- switch on the appliance at minimum temperature for 50 minutes without any food on the grill.

It is best to have an authorised customer assistance service perform maintenance and inspection on the appliance at least once a year to ensure top working and safety conditions.

Disposal at end of life

According to Art. 3 of the Decreto Legislativo n.49 of the Italian Legislation of the 2014 "Implementation of the WEEE Directive on Waste Electrical and Electronic Equipment 2012/19/EU".

- The WEEE symbol of a crossed out wheellie bin with a black line under it specifies that the product has been placed on the market after the 13th August 2005 and that at the end of its life it must not be disposed of together with other refuse but must be disposed of separately. All the equipment has been made with recyclable metal materials (stainless steel, iron, aluminium, zinc plate, copper, etc.) that as a percentage make

up more than 90% of the weight.

- The equipment must be made ready for disposal by removing the power cable and closing the door or any cavities (where present).

Attention must be paid to the management of this product at the end of its life, reducing any negative impact on the environment and improving the efficiency of resources, applying the principles of “who pollutes pays”, prevention, preparation for re-use, recycling and recovery. An Illegal or non-correct disposal of the product will lead to sanctions being applied as per current legislation.

- **Information on disposal in Italy**

In Italy all WEEE equipment must be delivered:

- to Collection Centres (also named “eco-islands” or “eco-platforms”)
- to the dealers from which new equipment has been purchased, who is bound to collect the old equipment free-of-charge (“one in one out” collection);

- **Information on disposal in European Union countries**

The EU Directives on WEEE equipment has been implemented in different ways by different countries, therefore in order to dispose of this equipment correctly we suggest that you contact your local authority or your dealer in order to ask the correct method of disposal.

After-sales assistance

In case of any malfunctions, disconnect the appliance from its power and contact a Spidocook S.r.l. authorised technical customer service. Provide the following information:

- the date of purchase;
- the appliance data on the serial plate.

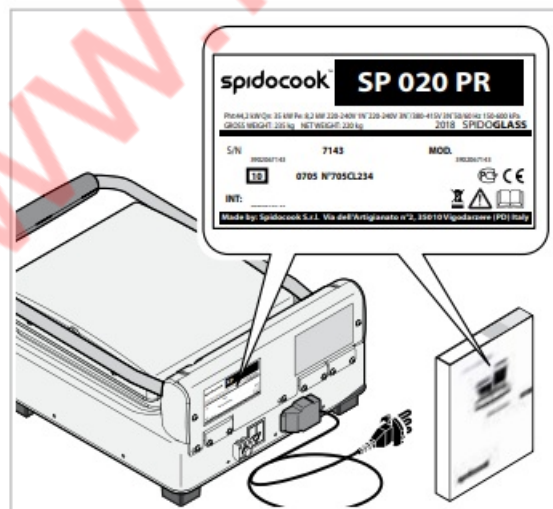

- **Manufacturer's information:**

Spidocook S.r.l.

Via dell'Artigianato n°2

35010 Vigodarzere (PD) Italy

info@spidocook.com

www.spidocook.com <<http://www.spidocook.com>>

Certification

EU declaration of conformity for electrical appliances

Manufacturer: Spidocook S.r.l.

Address: Via dell'Artigianato n°2, 35010 Vigodarzere (PD) Italy

Declares, under its own responsibility, that the product

SPIDOGLASS

complies with Low Voltage Directive 2006/95/EC and is built in compliance with the following standards:

EN 60335-1:2012 + A11:2014

EN 60335-2-38:2003 +A1:2008

EN 62233:2008

complies with EM Compatibility Directive 2004/108/EC and is built in compliance with the following standards:

EN 55014-1: 2006 + A1: 2009

EN 55014-2: 1997 + A1: 2001 + A2: 2008 + IS: 2007

EN 61000-3-2: 2006 + A1: 2009 + A2: 2009

EN 61000-3-3: 2008

Guarantee

Installation of the Spidocook S.r.l. product must be performed by an Authorised Spidocook S.r.l. Assistance Service. The installation date and appliance model must be documented by the end purchaser, by means of written confirmation or an installation invoice issued by the dealer or the Authorised Spidocook S.r.l. Customer Assistance Service, otherwise this guarantee will not be valid; The Spidocook S.r.l. guarantee covers all malfunctions objectively linked to production defects. The guarantee excludes damage due to transport, poor product storage or maintenance or incorrect product use. Also excluded is damage due to installation not conforming to the technical specifications provided by Spidocook S.r.l. and linked to the environment of use, such as, for example, unclean and aggressive water supply, low quality gas supply, or electrical supply failing to provide nominal voltage and power ratings.

The guarantee also excludes any damage due to power surges or tampering by unauthorised or incompetent persons. The guarantee is also invalidated for damage to the appliance by lime scale deposits. In addition, the guarantee does not cover consumables, such as: seals, light bulbs, glass panels, decorative parts and parts consumed during use. Guarantee rights will also be invalidated in the event of damage arising as a result of incorrect installation, or installation which has not been carried out by an Authorised Customer Assistance Service.

LI1811A3.D00-LDI-01 – Printed: 04-2019

All images used are for illustrative purposes only.

All features indicated in this catalogue may be subject to change and could be updated without notice.

Documents / Resources

 <p>SPIDOGLASS</p> <p>spidocook</p> <p>EMCA</p>	<p>spidocook 596040 SpidoGlass Double Ceramic Contact Grill [pdf] Instruction Manual 596040, 596042, 596045, 596047, 596050, 596052, 596055, 596057, SpidoGlass Double Ceramic Contact Grill, 596040 SpidoGlass Double Ceramic Contact Grill</p>
--	--

References

- [Spidocook](#)