



# R 600

## The potentialities of the series

RoboCream is a modern and convenient innovation in the the world of handcraft food preparations. It has more than 50 programs (automatic or customisable) to make custard cream, catalan cream, crème brulée, lemon cream, mousseline, diplomat, almond cream, butter cream, fruit cream, bavarian cream, pâte à bombe, choux pastry, confiture, jelly, gelatine, nappage, chocolate melting, ganache, chocolate sauce, tomato sauce, bechamel, risotto, polenta, etc. It pasteurizes ice cream mixes.



### TECHNICAL SUMMARY

<i>Custard cream per cycle L</i>	<i>7 / 60 ( 120 min)</i>
<i>Pasteurizing / Aging per cycle L</i>	<i>7 / 60 ( 120 min)</i>
<i>Condenser</i>	<i>Water</i>
<i>Nominal Power W</i>	<i>8000</i>
<i>Standard voltage</i>	<i>400V3N~50Hz</i>
<i>Net weight Kg.</i>	<i>230</i>
<i>Net Dimensions W x D x H mm</i>	<i>600x836x1335</i>

*\* Air or Mixed cooling on request (Depth increase 50 cm)*

### DIMENSIONS (mm)

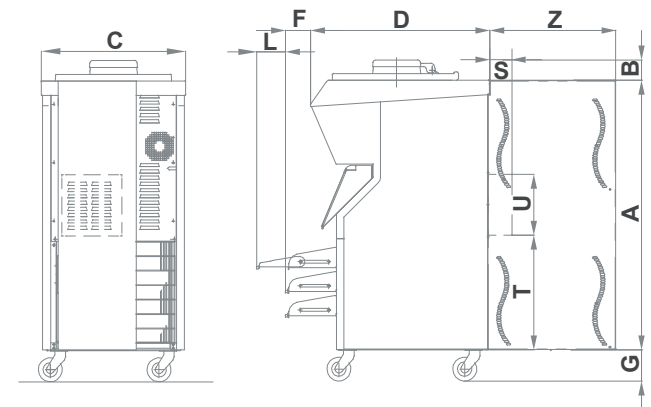

A	B	C	D	F	G	L
1120	80	600	744	92	130	120