

PASTOCREAM "R152"

Multifunction Machines for Confectionary and Gastronomy

Inverter technology

variable agitator speed, gear motor protection and energy saving



Adjustable stirrer speed in all programs

maximum capacity 15 liters

52 programs that includes:

Mixing program; for mixing, whipping, washing ...

Cooling programs; allows to choose the ideal cycle, depending on the kind of mix used (milk, fruit ingredients). For cooling ingredients

Pasteurizing programs for HACCP regulations;

high, medium, low, chocolate programs. For the pasteurizing of ice cream mixes; heating of the mix up to 95°C, and the following cooling down to 4°C. An acoustic signal informs you about the end of the whole cycle. Now the aging/conservation cycle starts, the constant temperature of the mix will be 4°C. The stirrer can be used continuously or intermittently. The cycle works completely automatically also in case of a black out. High pasteurization 85°C with cooling down 4°C of 15 Lts ice cream mix: in 80 minutes.

Free programs; allows to create the recipes by modifying the following parameters:

- · heating temperature (for recipes up to 115°C approx)
- · cooling temperature (for recipes up to -3°C approx)
- · the time of pause at the high temperature
- · the stirrer on/off during the heating and the cooling phase

For preparing custard cream, jams, choux pastry, gelatine, rice for pastry, béchamel/white sauce, sauces....

Model	R152A	R152W	R151AW
Bowl capacity L	18	18	18
PASTEURIZING DETAILS for ice cream mix or custard cream			
Max production	15 kg in 80 minutes	15 kg in 80 minutes	15 kg in 80 minutes
Min quantity per cycle kg.	5	5	5
Max quantity per cycle kg.	15	15	15
TECHNICAL DETAILS			
Condenser	air	water	mixed
Standard voltage	230V – 50Hz –1pH	230V – 50Hz –1pH	230V – 50Hz –1pH
Power W	3300	3300	3300
Net weight	147	147	150
Dimensions L x W x H mm	600 x 850 x 1335	600 x 850 x 1335	600 x 850 x 1335

The production may vary in relation to the temperatures and type of products



R 152

The potentialities of the series

RoboCream is a modern and convenient innovation in the the world of handcraft food preparations. It has more than 50 programs (automatic or customisable) to make custard cream, catalan cream, crème brulée, lemon cream, mousseline, diplomat, almond cream, butter cream, fruit cream, bavarian cream, pâte à bombe, choux pastry, confiture, jelly, gelatine, nappage, chocolate melting, ganache, chocolate sauce, tomato sauce, bechamel, risotto, polenta, etc. It pasteurizes ice cream mixes.



TECHNICAL SUMMARY

<i>Custard cream per cycle L</i>	<i>3 / 15 (80 min)</i>
<i>Pasteurizing / Aging per cycle L</i>	<i>3 / 15 (80 min)</i>
<i>Condenser</i>	<i>Air or Water or Mixed</i>
<i>Nominal Power W</i>	<i>3300</i>
<i>Standard voltage</i>	<i>230V~50Hz</i>
<i>Net weight Kg.</i>	<i>138</i>
<i>Net Dimensions W x D x H mm</i>	<i>600x836x1335</i>

DIMENSIONS (mm)

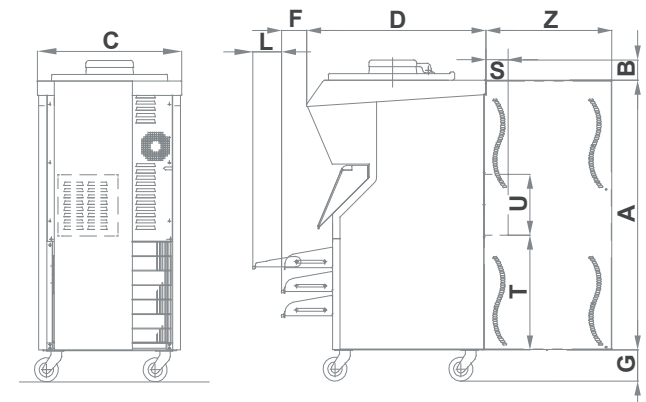

A	B	C	D	F	G	L
1120	80	600	744	92	130	120