



JUNIOR SERIES

COMBI 225

Ref : MX022



DESCRIPTION

- Lightweight, sturdy and handy.
- Detachable mixer tool and whisks for easy cleaning and maintenance.
- Safety button.
- Double insulation.
- Variable speed as standard.
- Stainless steel mixer tube and guard for easy cleaning and perfect hygiene.
- Titanium-plated blade easy to remove.



USE

Mixer : It allows to mix, directly in the pots, many applications including : fish soups, panades (thick soup reduced to puree), salad dressings, pancakes paste, gravies, sauces, mayonnaise, puree of vegetables lightly pulverized, porridge, raw carrots puree, fruits cream ...

Whisks : To prepare batters, creams and mousselines easily.

Capacity : 5 to 25 Liters (mixer) / 1 to 5 Liters (whisks)

MAINTENANCE

Clean the outside of the tube and the blade protector by passing it under the faucet.

Dismantle whisks from their attachments by pushing strongly on the cups, then you can securely rinse the whisks under running water.

Wash the motor block with a sponge or with a slightly damp cloth.

Never clean this machine with water jet spray or in the dishwasher.

Use the wall mount to store your device.



TECHNICAL DATA

OUTPUT MAX	270 W
SPEED	3000 to 12000 R.P.M.
VOLTAGE	110 - 120 V or 220 - 240 V
TOTAL LENGTH	530 mm
SHAFT LENGTH	225 mm
WHISKS LENGTH	185 mm
DIAMETER	94 mm
ACTUAL WEIGHT	3 kg

www.dynamicmixers.com

Dynamic - 518 rue Léo Baekeland BP57 - 85290 Mortagne sur Sèvre

Tél : +33 (0)2 51 63 02 72 • E-mail : contact@dynamicmixers.com

Follow us on social networks !



ACCESSORIES



STANDARD MOTOR BLOCK



Ref. : **AC100**

CAPACITY	5 to 25 Liters
SHAFT LENGTH	225 mm
SPEED R.P.M.	3 000 / 12 000

CAPACITY	1 to 10 Liters
SHAFT LENGTH	225 mm
SPEED R.P.M.	3 000 / 12 000

CAPACITY	1 to 4 Liters
WHISKS LENGTH	185 mm
SPEED R.P.M.	600 / 2 500

CAPACITY	1 to 10 kg
SHAFT LENGTH	300 mm
SPEED R.P.M.	70 / 300

CAPACITY	0,8 Liter
HEIGHT	200 mm
SPEED R.P.M.	600 / 2 500

Mixer tool



Ref. : **AC101**

Blender tool



Ref. : **AC066**

Extractable whisks



Ref. : **AC102**

Ricer tool



Ref. : **AC103**

Cutter bowl



Ref. : **AC104**

4010-4010.1-4030-4030.1

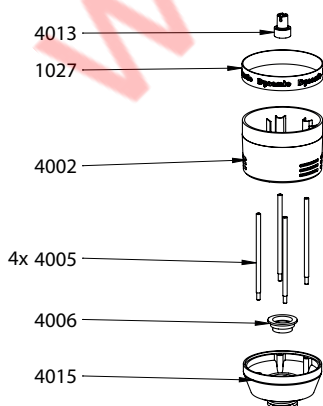
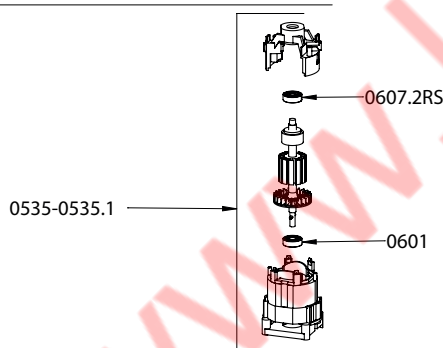
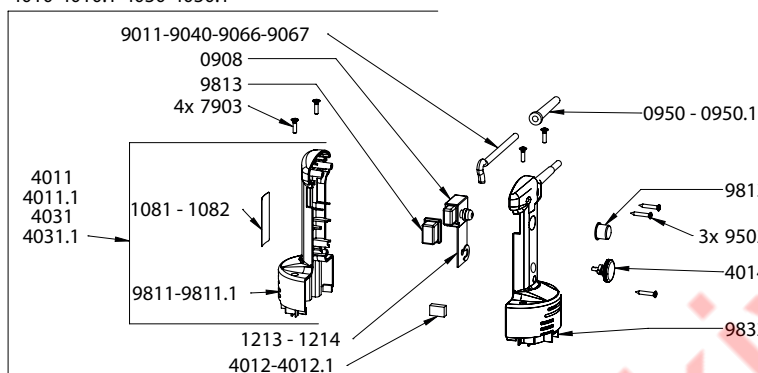

Parts list

Code

Stator 230 V	0535
Stator 115 V	0535.1
Lower ball bearing motor	0601
Upper ball bearing motor	0607.2RS
Wall bracket	0880.1
Non-locking switch	0908
Strain relief 230 V	0950
Strain relief 115 V	0950.1
Dynamic label	1027
Id label (Junior Plus) 230V	1084
Id label (Junior Plus) 115V	1085
Id label (Junior Combi) 230V	1086
Id label (Junior Combi) 115V	1087
Speed variator 230V	1213
Speed variator 115V	1214
Upper motor housing	4002
Braces (4)	4005
Ball bearing ring	4006
Complete handle w/ power cord 230V	4010
Complete handle w/ power cord 115V	4010.1
Lower half handle w/ Junior Plus label 230V	4011
Lower half handle w/ Junior Plus label 115V	4011.1
Filtering capacitor 230 V	4012
Filtering capacitor 115 V	4012.1
Coupling	4013
Speed variator knob	4014
Lower aluminium motor housing	4015
Complete handle w/ power cord 230V	4030
Complete handle w/ power cord 115V	4030.1
Lower half handle w/ Junior Combi label 230V	4031
Lower half handle w/ Junior Combi label 115V	4031.1
Carbon brushes (2) 230 V	4050
Carbon brushes (2) 115 V	4050.1
Brace screws (4)	7903
Power cord 230 V	9011
Power cord 115 V	9040
Power cord (Australia)	9066
Power cord (UK)	9067
Handle screws (3)	9502
Switch protector	9813
Upper half handle Junior Plus & Junior Combi	9832

TECHNICAL SHEET

M 225 - Ref AC101 (Complete attachment)

Parts list Code

Ball bearing	0601
Waterproof seal	0632
Self-lubricating ring	0642
Bearing only	0898
Cutter blade	4004
Emulsifying blade	4009
Foot assembly with bearing	4016
Kit w/ shaft lower ball bearing and coupling	4017
Ball bearing ring	4018
Coupling hub	45123

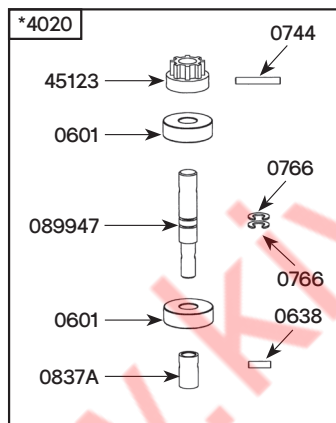
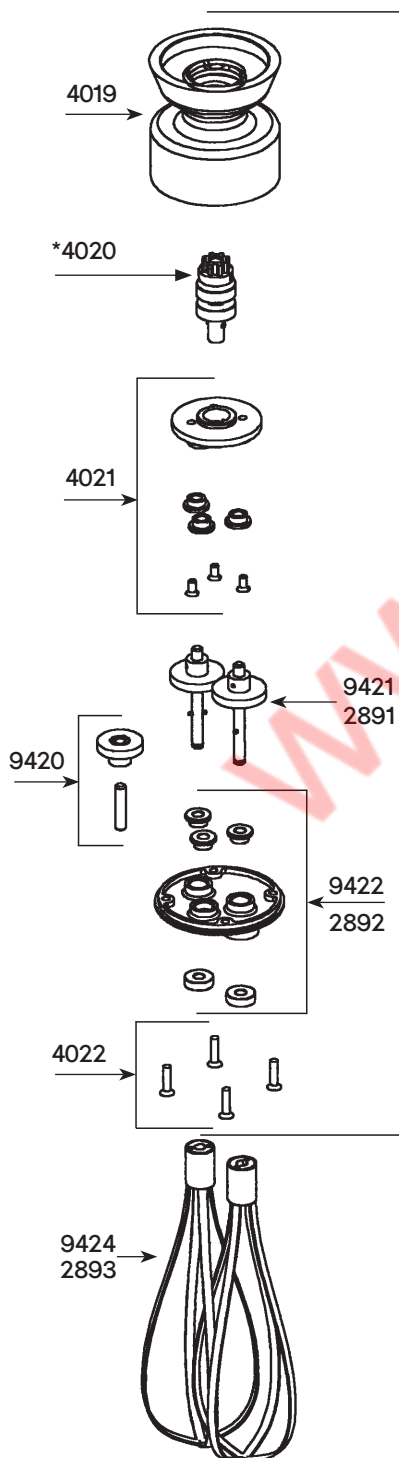
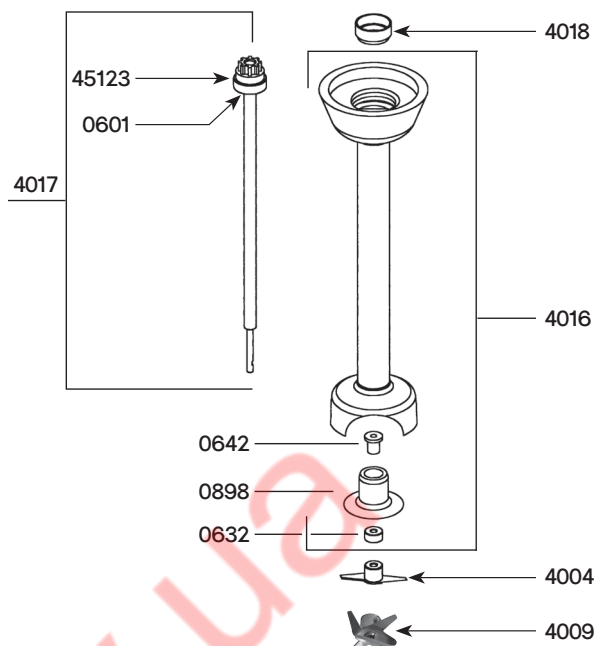

Parts list Code

Ball bearing	0601
Pins 3 x 10	0638
Pins 3 x 20	0744
Open head locking washer (unit)	0766
Entry gear	0837A
Lower motor whisk housing	4019
Equipped upper shaft (complete)	4020
Plate w/ seals and screws	4021
Holder assembly screws (4)	4022
Reduction gear assembly	4025
Middle gear & shaft	9420
Equipped output axle w/ 2 gears+pins	9421
Holder assembly w/ 3 self-lubricating rings	9422
Whisk tool (2)	9424
Coupling hub	45123
Upper driving shaft	089947

Extractable version (from 01/01/2105)

Equipped output shaft w/2gears + pins	2891
Holder assembly w/ 3 self-lubricating rings	2892
Whisks (2)	2893