



Self-contained ice maker - Paddle system Daily production up to 28 kg

Hotel	████████████████████
Restaurant	████████████████████
Fast food	████████████████████
Bar	████████████████████
Disco	████████████████████
Fish market	████████████████████
Supermarket	████████████████████
Medical & SPA	████████████████████
Industry	████████████████████

► Position n°



► Features & Plus

- Hollow cube
- AISI 304 SS Scotch Brite finish
- Tropical class +43°C
- Removable and cleanable air filter
- Air or water cooling system
- Easy cleanable internal rounded surfaces
- HCFC-Free insulated storage
- FDA approved - ABS water basin
- Basin tipping safety system
- RoHS Free
- Disappearing insulated door
- Electromechanical operation
- ON-OFF rocker switch
- Automatic water charge
- Standard and special voltages



AISI 304 SS Scotch Brite finish



Removable and cleanable air filter



FDA approved - ABS water basin



Disappearing insulated door

► Available ice cube size

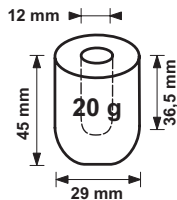

► Prod. 24h

Air temp.	Water temp.		kg	lbs	
	10° C	50° F			7° C
10° C	50° F	7° C	45° F	28	62
21° C	70° F	15° C	60° F	25	55

2 Years Warranty
subject to limitations

► Certifications available for this model





Ice Finger

IMF 26



Self-contained ice maker - Paddle system Daily production up to 28 kg

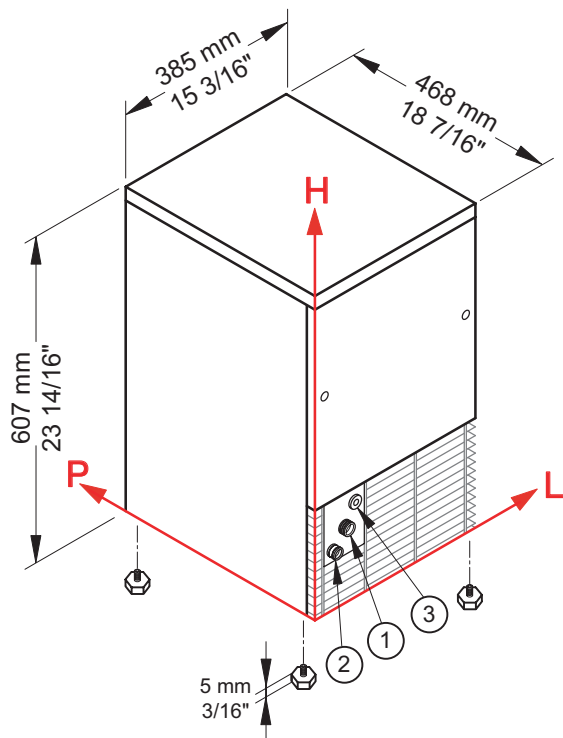

► Working conditions

- Location: **Indoor**

	Min	Max
Ambient temperature	+10° C / +50° F	+43° C / 110° F
Water temperature	+3° C / +37° F	+32° C / +90° F
Voltage	-10%	+10%
Water inlet pressure	1bar (14 psi)	6bar (84 psi)

► Performances

	Air temperature	Water temperature					
		7° C	45° F	15° C	60° F	21° C	70° F
	10° C	28 kg					
	50° F		62 lbs				
	21° C			25 kg			
	70° F				55 lbs		
	32° C					17 kg	
	90° F						37 lbs

► Connections

All measures are referred to the rear bottom-left corner (L-H-Ø)

- ① Water in.: 111 mm / 4 6/16" - 175 mm / 6 14/16" - 3/4" ② Water out.: 49 mm / 1 15/16" - 130 mm / 5 2/16" - 24 mm / 15/16"
 ③ Electrical connections: 156 mm / 6 2/16" - 211 mm / 8 5/16"

► Technical information

Production in 24h	25 kg / 55 lbs
Store capacity, up to	4 kg / 9 lbs
Cooling system	A - W
Kind of cube	A-20g
Refrigerant	R404A - R452A
Standard voltage	220-240 V ~ 50 Hz
Average power consumption	310 W
Fuse	10 A
Finish	AISI 304 stainless steel, scotch brite

Water consumption	A: 4,5 l/kg - 53,9 gal/100 lbs
	W: 15,5 l/kg - 185,7 gal/100 lbs
Sizes (L-P-H mm)	385 - 468 - 607
(L-P-H in)	15 3/16 - 18 7/16 - 23 14/16
Sizes with pack (L-P-H mm)	440 - 520 - 800
(L-P-H in)	17 5/16 - 20 8/16 - 31 8/16
Net weight	36 kg / 79 lbs
Gross weight	42 kg / 93 lbs

All the technical information must be considered at the following conditions:

- Sizes without feet
- Standard Cube (20 g)
- Ambient temperature +21° C
- Water temperature +15° C
- Average power consumption at +43° C (standard voltage)

Models and specifications are subject to change without notice

Rev. 04 - Issued September 2019



www.bremaice.it
info@bremaice.it

Bim + Data
download

