

**DRY AGER®** – The leading brand for professional, plug-in Dry Aging cabinets for the production and storage of **Dry Aged Beef, Dry Aged Pork, ham, salami, fish, cheese and much more.** The DX 1000 Premium S (220 - 240V, 2A) is suitable for use in both the commercial and private sectors. Thanks to innovative systems like SmartAging® technology, perfect aging results for a wide variety of foods can be achieved at the push of a button. The temperature can be electronically regulated in the range from 0 to +30°C, as can the humidity, in the range from 40 to 90 %, thanks to the built-in standard HumiControl® system. The device does not need a water connection or a water tank, which are just two of the many unique selling points. The **DX AirReg® system** also ensures an optimum air flow.

The built-in **activated carbon filter**, the unique **UVC sterilisation box** and **antibacterial inner container** give bacteria and germs no chance. Professional Dry Aging at the highest level, even with large fluctuations in ambient temperatures. The outside of the device is made of high-quality, rust-free stainless steel, while the polished black stainless steel rear wall on the inside also underlines the premium character. Contemporary, modern design on the outside – high-precision, sophisticated technology on the inside. The DRY AGER® Dry Aging cabinet can be set up free-standing as a single device or double device (side by side) or integrated in a wall. Commercial and private customers receive a 2-year full guarantee from the date of purchase. Quality made in Germany!



Nº 1 | WORLDWIDE



### Technology & equipment

#### Aging programme

- SmartAging® technology – smart programme control enables Dry Aging with the help of product-specific aging programmes.
- Optimum parameter settings are carried out automatically by the SmartAging® processor and guarantee ideal results at the push of a button.

#### Temperature & humidity

- HumiControl® – constant humidity, electronically adjustable from 40 to 90 % (no water connection or tank required).
- Electronically controlled temperature from 0 to +30°C.
- Professional dry aging with minimum weight loss.
- Automatic defrost and automatic condensation evaporation.

#### Hygiene

- UVC sterilisation system, DX AirReg® system and activated carbon filter – optimum air flow and air quality without UV exposure of the products.
- Antibacterial inner container – the shape of the side shelf supports and rounded corners make cleaning easier.

#### Visual design

- Housing & door frame made of stainless steel.
- Black steel rear panel, brushed black stainless steel.
- Dimmable DX-LED side and ceiling lighting – optimum illumination of the presented products.
- Attractive aesthetics with sales promotion potential.

#### Modularity

- Built-in or free-standing – enables the integration of single or multiple units next to each other.
- Door hinge possible on both sides.

#### Accessories supplied

- 1 x hanger (DX0011) – made of stainless steel, max. load capacity 80 kg (the picture shows 2x hangers).

#### Guarantee

- 2 year full guarantee for private and commercial customers.
- 3 year full guarantee available on request.



# DRY AGER® DX 1000 PREMIUM S

for up to 100 kg load

## Technical specifications

Gross net content	495 / 435l	Housing	Stainless steel
Maximum load	100 kg	Insulating glass door	Stainless steel, metallised glass (UV protection), robust door handle
Inner dimensions	137.1 x 57.8 x 58.7 cm (HxWxD)	Inner container	Antibacterial polystyrene plastic
External dimensions	165.0 x 70.0 x 74.2 cm (HxWxD)	Rear wall inside	brushed black stainless steel
Temperature range	0 °C to +30 °C, electronically adjustable in increments of 0.1 °C	Visual & acoustic alarm	Yes
HumiControl®	40 % to 90 %	Installation of one or more devices in the wall or as a free-standing device possible	Yes
Mains connection	220-240V / 2A / 50Hz	Refrigerant	R600a
Power consumption	~1.8 kWh / 24h	Unladen weight	88 kg
UVC sterilisation and activated carbon filter	Yes	Shipping weight (on pallet)	104 kg
SmartAging® control	Yes	Shipping dimensions (on pallet)	185.0 x 80.0 x 120.0 cm (HxWxD)
Water connection or tank necessary	No	Device article number	DX1000PS
Automatic defrost	Yes		
Automatic condensate evaporation	Yes		

## Application: filled with meat



Beef on slide-in shelves



Two loins of beef hanging



Saddle of pork and beef hanging



Beef on slide-in shelves and pork hanging underneath

# DRY AGER® DX 1000 PREMIUM S

for up to 100 kg load

Further applications: one DRY AGER Dry Aging cabinet – many possible uses



Dry Aging of meat



Production of sausage and salami



Production of ham



Dry Aging of poultry



Dry Aging of fish and seafood



Production and storage of cheese | Tempering of champagne and wine  
**NEW:** Special wooden slide-in shelves are available for this application.

# DRY AGER® DX 1000 PREMIUM S

for up to 100 kg load

## Drawings

Front view

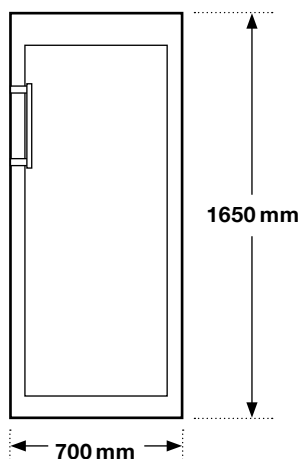

Top view

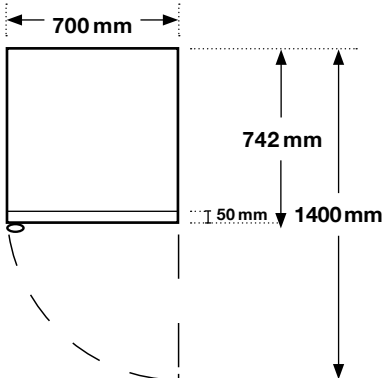

## Integration drawings

Installation of one device

Installation of several devices (side by side)

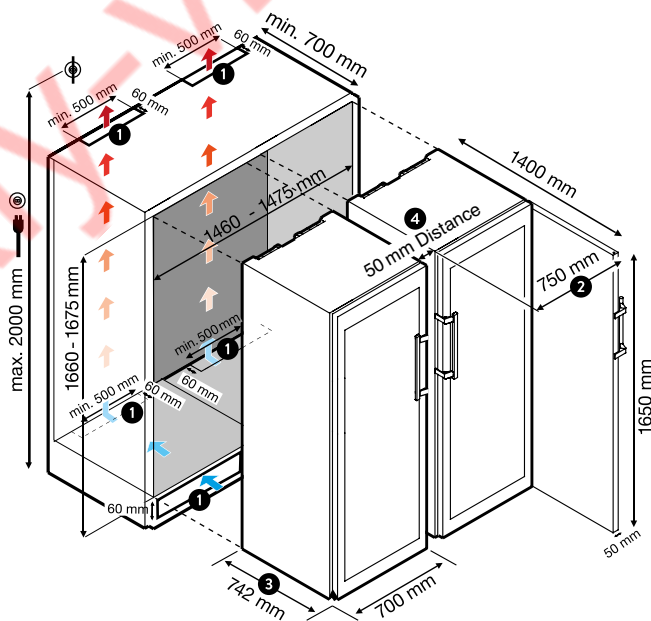
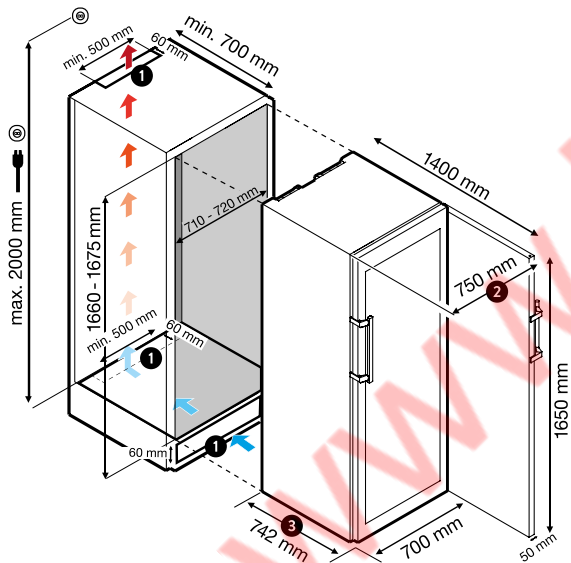

- 1 Ventilation shaft is mandatory. Minimum size: **300 cm<sup>2</sup>**. Also possible on the side or on the back wall.
- 2 Overall dimensions (width) with the door open including handle: **750 mm**
- 3 Overall dimensions (depth) body + closed door (protruding): **742 mm**
- 4 Panelling of the intermediate gap with DRY AGER® stainless steel cover possible (DX0030).

# DRY AGER® DX 1000 PREMIUM S

## for up to 100 kg load

### Optional accessories for DX 1000 Premium S

#### Device accessories

- DX0011 Hangers**  
made of stainless steel, enables larger parts to be hung up using S-hooks, loadable up to 80 kg.
- DX0015 Half slide-in shelf**  
takes up only half of the DRY AGER depth, can be loaded up to 25 kg.
- DX0020 Slide-in shelf**  
enables food to be aged and stored horizontally, with a load capacity of up to 40 kg.
- DX0022 Slide-in shelf for sausages and ham**  
for hanging and aging sausages and ham, loadable up to 20 kg. 
- DX0024 Slide-in shelf for cheese & wine set**  
made of wood, 5 pieces in a set (1 x half shelf + 4 x whole shelf), perfect for cheese and wine.
- DX0055 Saltair salt block set**  
real salt, supports the process in the device and ensures an appealing look, 4 blocks in the set.
- DX0070 Saltair salt tray**  
made of stainless steel, perfect fit for Saltair salt block set (DX0055).
- DX0030 Stainless steel panel**  
for covering the gap between two DX1000 Premium S units arranged next to each other.
- DX0080 Podium**  
matt black, 40 cm high, metal version, powder-coated, without wheels
- DX0082 Podium with wheels**  
matt black, 40 cm high, metal version, powder-coated, with swivel wheels (50 cm total height)



Further accessories, knives, saws, machines for meat processing and much more can be found online: [www.dry-ager.com](http://www.dry-ager.com)

#### Accessories

- Z44044 S-hook**  
made of stainless steel, size 160 x 8 mm, loadable up to 100 kg.
- Z44055 Swivel hook**  
made of stainless steel, size 180 x 8 mm, loadable up to 100 kg.
- DX0040 Labels for writing on meat**  
20 pieces, including skewers for attachment, food-safe & reusable.
- Z33145 DRY AGER® Special cleaner**  
Cleaning solution in 500 ml spray bottle.

#### Servicing and maintenance

- DX0101 UVC replacement bulb (UVC2)**  
for the annual maintenance of the UVC sterilisation box.
- DX0110 Activated carbon filter**  
for the annual replacement.

#### Awards



Information Print Product:  
Item no.: WD0075



4 251309 913287

Landig + Lava GmbH & Co. KG – We will be happy to provide you with further information on request.  
Subject to technical modifications and printing errors. Last updated: 12/2021

