



R151 MAX

The potentialities of the series

RoboCream is a modern and convenient innovation in the the world of handcraft food preparations. It has more than 50 programs (automatic or customisable) to make custard cream, catalan cream, crème brulée, lemon cream, mousseline, diplomat, almond cream, butter cream, fruit cream, bavarian cream, pâte à bombe, choux pastry, confiture, jelly, gelatine, nappage, chocolate melting, ganache, chocolate sauce, tomato sauce, bechamel, risotto, polenta, etc. It pasteurizes ice cream mixes. It makes gelato and fresh sorbets.



TECHNICAL SUMMARY

<i>Custard cream per cycle L</i>	3 / 15 (50 min)
<i>Pasteurizing / Aging per cycle L</i>	3 / 15 (50 min)
<i>Quantity per batch introduced Kg</i>	2,3 / 8
<i>Quantity per batch introduced L</i>	2 / 7
<i>Max Hourly gelato produced L</i>	60
<i>Max Hourly gelato produced Kg</i>	48
<i>Min quantity per batch produced (L)</i>	2,6
<i>Max quantity per batch produced (L)</i>	10
<i>Condenser</i>	Air or Water or Mixed
<i>Nominal Power W</i>	5800
<i>Standard voltage</i>	400V3N~50Hz
<i>Net weight Kg.</i>	215
<i>Net Dimensions W x D x H mm</i>	600x836x1335

DIMENSIONS (mm)

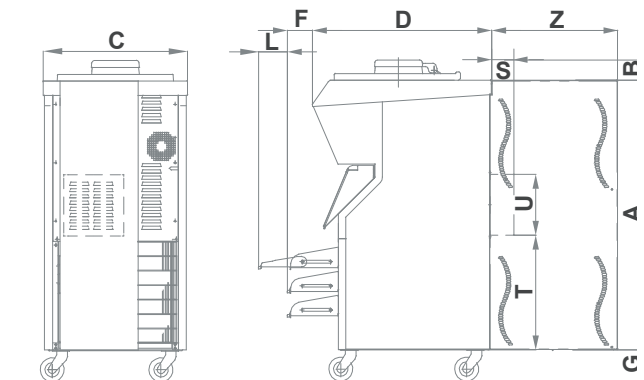

A	B	C	D	F	G	L
1120	80	600	744	92	130	120