

Gastro-Line Counters

Users manual



Models:

- CK-I Series
- CF-P Series
- SK-I Series
- SK-P Series
- BK-I Series
- UC-I Series
- SS-P Series
- PT-I Series

EN 1

DE 9

DK 17

SV 25

FR 33

IT 41

ES 49

PT 57

RUS 65

‘Gastro-Line’ Столы

Руководство пользователя



МОДЕЛИ:

СК-І
СF-Р
SK-І
SK-Р
BK-І
UC-І
SS-Р
PT-І

СОДЕРЖАНИЕ

1.

содержание

| | |
|--------------------------------|----|
| Внимание..... | 68 |
| Распаковка и установка | 68 |
| Подключение к электросети..... | 69 |
| Запуск | 69 |
| Термостат | 70 |
| Размораживание | 71 |
| Техобслуживание..... | 71 |
| Устранение неполадок | 71 |
| Утилизация..... | 71 |
| Электрическая схема | 73 |

2.

Техническое руководство по термостату

| | |
|----------------------|----|
| Dixell XW20LRH | 74 |
| Dixell XW60LRH | 79 |

www.kiyv.ua

ВНИМАНИЕ

1. Перед использованием Бэк-бара необходимо прочитать инструкцию.
2. Пользователь несёт ответственность за использование Бэк-бара в соответствии с инструкциями.
3. В случае неполадок свяжитесь с дистрибьютором.
4. Бэк-бар должен быть расположен в сухом и хорошо проветриваемом помещении.
5. Не допускается установка изделия вблизи источников теплового излучения, т.е. плит, батарей отопления и т.п., а также в местах действия прямых солнечных лучей.
6. Обратите внимание на то, что любой электрический аппарат может быть опасным.
7. Нельзя использовать для хранения взрывоопасных веществ, таких как например газ, бензин и т.п.
8. В конструкции изделия не использованы асбест или CFC.
9. Компрессорное масло не содержит PCB



Этот шкаф содержит горючий хладагент.

Внимание!

Основа этого холодильника предназначена для герметично запечатанных контейнеров с обработанными пищевыми продуктами (EN 16825).

РАСПАКОВКА И УСТАНОВКА

Бэк-бар поставляется в упакованном виде. Перед тем как распаковать, проверьте если нет повреждений на упаковке.

ПОДКЛЮЧЕНИЕ К ЭЛЕКТРОСЕТИ

Бэк-бар должен быть подключён к питающей электрической сети 230 V/50 Hz.

Розетка должна находиться в легко доступном месте. Подключение к электросети допускается только через стационарную розетку или удлинитель с заземляющим проводом.

ЗАПУСК

Перед использованием Бэк-бар необходимо почистить, см. раздел «Обслуживание».

Внимание!

Если Бэк-бар при перевозке находился в лежачем состоянии, подождите 2 часа до того как включать его в электросеть.

ТЕРМОСТАТ

Термостат находится на контрольной панели



Термостат запрограммирован, поэтому нет необходимости в его настройке. При включении стола, на экране дисплея появится актуальная внутренняя температура стола.

Показ внутренней температуры:

SET Нажмите на данную кнопку и на экране дисплея покажется настроенная температура. Чтобы вернуться в исходное положение надо ещё раз нажать на кнопку.

Настройка температуры:

SET Нажмите на кнопку более 3 секунд пока на дисплее не появится настроенная температура.



При нажатии на данную кнопку, температура возрастает.



При нажатии на данную кнопку, температура снижается.

SET Нажмите на эту кнопку, чтобы запомнить/зарегистрировать новые данные.

Блокирование кнопок :



Для избежания случайных нажиманий на кнопки, их блокируют. Для этого нажмите одновременно на обе кнопки в течение 5 секунд пока на экране не появится «Pof». Для разблокирования повторите тоже самое, пока на экране не появится «Pon»

Аварийная сигнализация:

‘P1’ Мигающая лампа указывает на повреждение датчика.

‘P2’ Мигающая лампа указывает что повреждён датчик испарителя.

РЕГУЛИРОВАНИЕ ТЕМПЕРАТУРЫ

См.таблицу параметров на стр. 74.

РАЗМОРАЖИВАНИЕ СТОЛА

Стол размораживается автоматически с запрограммированными интервалами. В случае частого открывания дверцы стола может возникнуть необходимость ручного размораживания



Механическое размораживание запускается при помощи нажатия на данную кнопку более 3 секунд, после чего изделие запускается как обычно.

Оттаявшая вода стекается в ванночку расположенную в компрессорном отделе.

ТЕХОБСЛУЖИВАНИЕ

Отключите Бэк-бар от сети.

Бэк-бар необходимо регулярно чистить. Мойка изделия производится теплой водой с небольшим количеством мыльного средства. После чего Бэк-бар промыть чистой водой и просушить.

ЗАПРЕЩАЕТСЯ использовать хлоросодержащие моющие средства или другие едкие средства, которые могут повредить работе Бэк-бара.

УСТРАНЕНИЕ НЕПОЛАДОК

При неполадках в холодильной системе проверьте вставлена ли вилка в розетку и подключена ли розетка, а также если нет неполадков в сети.

Если причину неисправности не возможно выяснить, обратитесь к дилеру. Обращаясь к дилеру, назовите модель холодильника, серийный номер и номер изделия. Эти данные указаны на заводской табличке с правой стороны на внутренней панели шкафа.

УТИЛИЗАЦИЯ

Если срок эксплуатации изделия подошёл к концу, его следует утилизировать без нанесения вреда окружающей среде. Следует принимать во внимание существующие правила утилизации. Помимо этого могут существовать определённые законодательные требования по утилизации, которым тоже необходимо следовать.



COOLERS

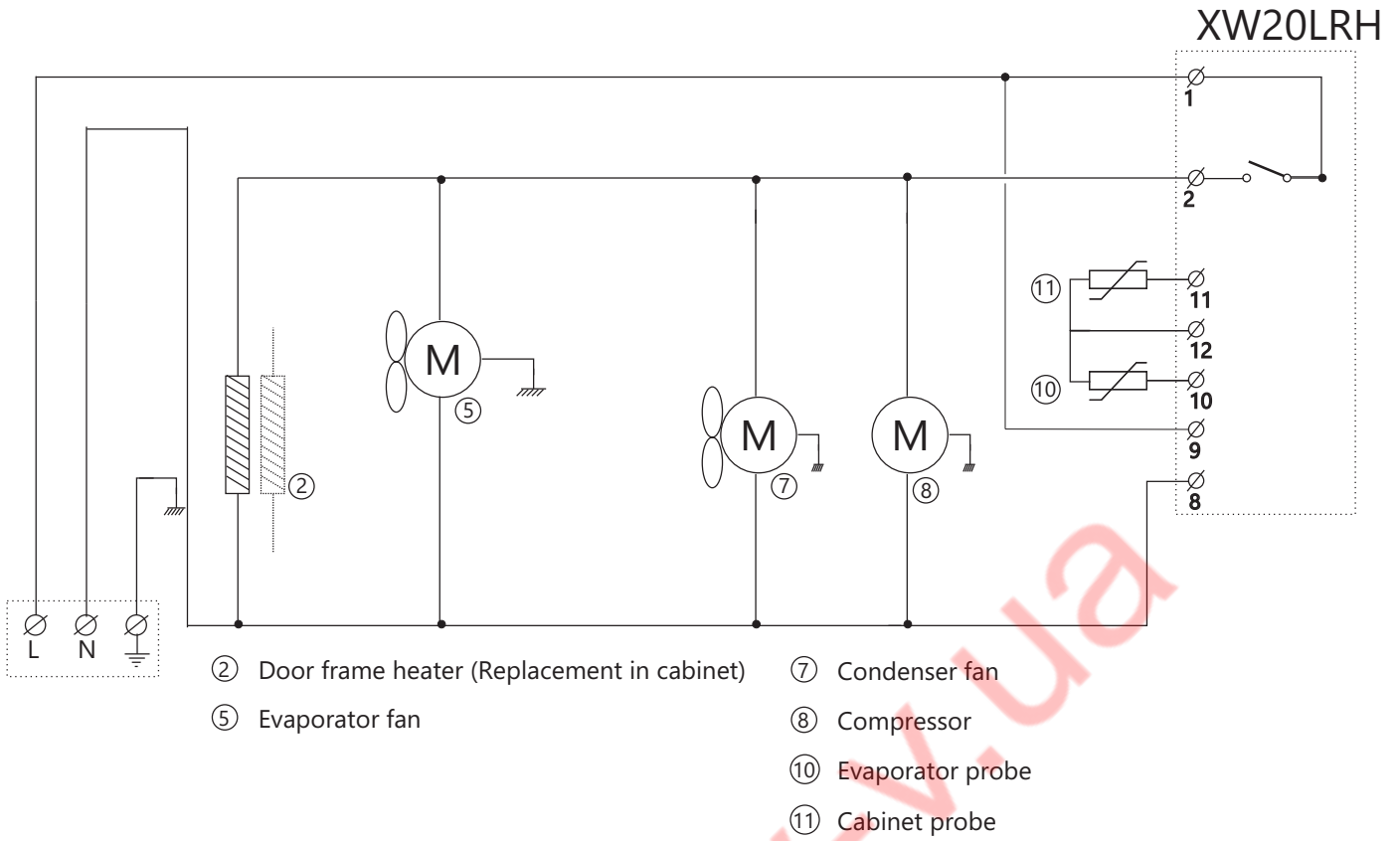

FREEZERS

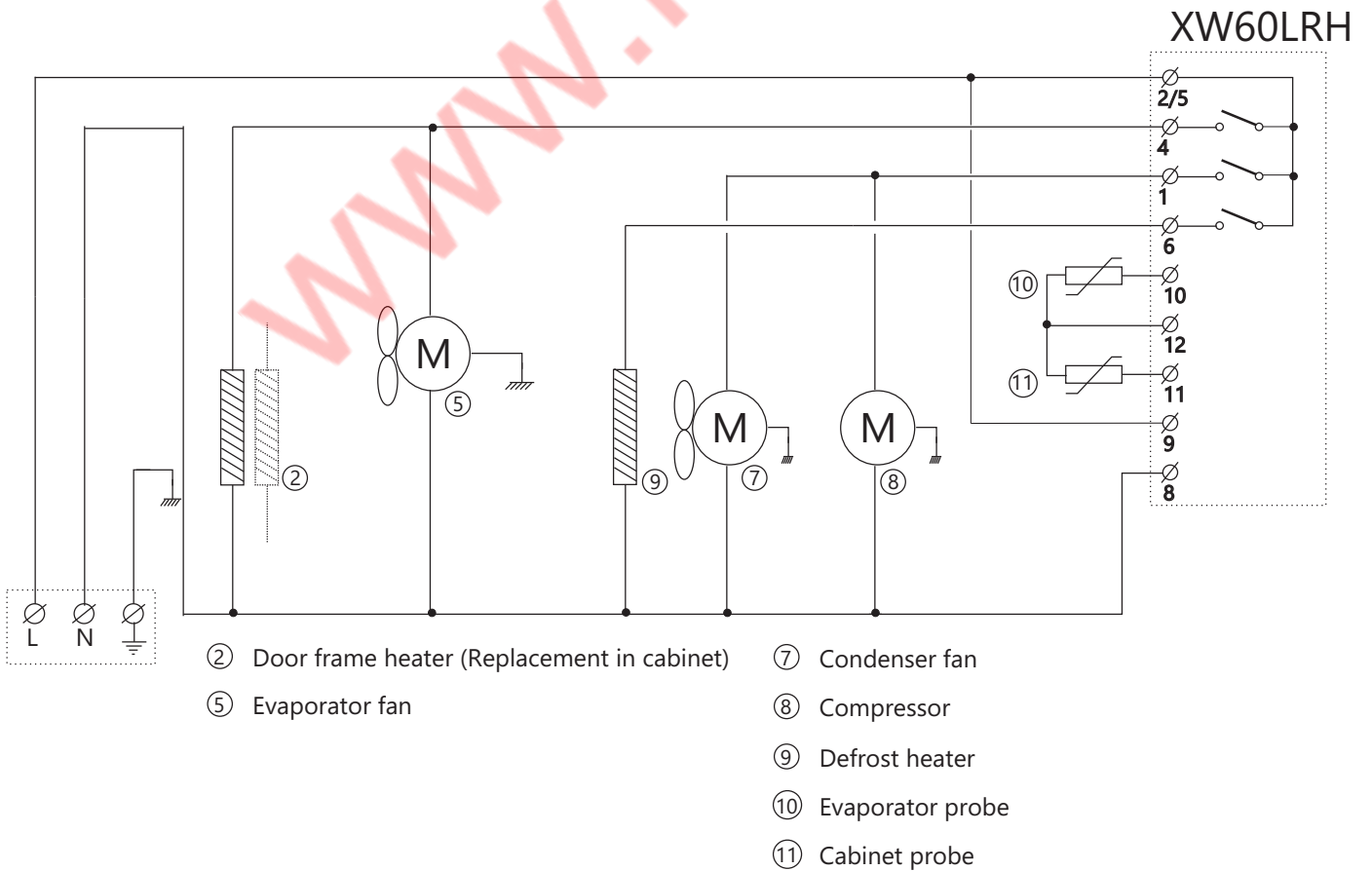

Digital controller with off cycle defrost and auxiliary relay
XW20LR –XW20LRH

1. GENERAL WARNING

1.1 PLEASE READ BEFORE USING THIS MANUAL

- This manual is part of the product and should be kept near the instrument for easy and quick reference.
- The instrument shall not be used for purposes different from those described hereunder. It cannot be used as a safety device.
- Check the application limits before proceeding.
- Dixell Srl reserves the right to change the composition of its products, even without notice, ensuring the same and unchanged functionality.

1.2 SAFETY PRECAUTIONS

- Check the supply voltage is correct before connecting the instrument.
- Do not expose to water or moisture: use the controller only within the operating limits avoiding sudden temperature changes with high atmospheric humidity to prevent formation of condensation
- Warning: disconnect all electrical connections before any kind of maintenance.
- Fit the probe where it is not accessible by the End User. The instrument must not be opened.
- In case of failure or faulty operation send the instrument back to the distributor or to "Dixell S.r.l." (see address) with a detailed description of the fault.
- Consider the maximum current which can be applied to each relay (see Technical Data).
- Ensure that the wires for probes, loads and the power supply are separated and far enough from each other, without crossing or intertwining.
- In case of applications in industrial environments, the use of mains filters (our mod. FT1) in parallel with inductive loads could be useful.
- Dixell Srl reserves the right to change the composition of its products, even without notice, ensuring the same and unchanged functionality.

2. GENERAL DESCRIPTION

Model **XW20LR, XW20LRH**, format 38x185mm, is a digital thermostat with off cycle defrost designed for refrigeration applications at medium and low temperature. It has 2 relay outputs, one to control compressor and the other (configurable) to control light, auxiliary or alarm. It could be provided with a Real Time Clock which allows programming of up to 6 daily defrost cycles, divided into holidays and workdays. A "Day and Night" function with two different set points is fitted for energy saving. It is also provided with up to three NTC or PTC probe inputs, the first one for temperature control, the second one, to be located onto the evaporator and to control the defrost termination temperature. The third probe is used to signal the condenser temperature alarm or to display a temperature. One of the 2 digital inputs can operate as fourth probe input.

The HOT KEY output allows to connect the unit, by means of the external module XJ485-CX, to a network line ModBUS-RTU compatible such as the **dixell** monitoring units of X-WEB family. It allows to program the controller by means the HOT KEY programming keyboard.

The instrument is fully configurable through special parameters that can be easily programmed through the keyboard.

3. CONTROLLING LOADS

3.1 COMPRESSOR

The regulation is performed according to the temperature measured by the thermostat probe with a positive differential from the set point: if the temperature increases and reaches set point plus differential the compressor is started and then turned off when the temperature reaches the set point value again.

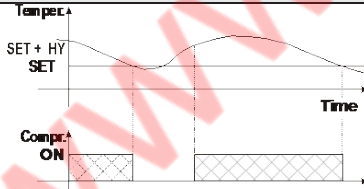

In case of fault in the thermostat probe the start and stop of the compressor are timed through parameters "CON" and "COF".

3.2 DEFROST

Defrost is performed through a simple stop of the compressor. The defrost interval depends on the presence of the RTC (optional). If the RTC is present is controlled by means of parameter "EdF":
 - with EdF=in the defrost is made every "ldF" time – standard way for controller without RTC.
 - with EdF = "rtc", the defrost is made in real time depending on the hours set in the parameters Ld1...Ld6 on workdays and in Sd1...Sd6 in holidays;

Other parameters are used to control defrost cycles: its maximum length (MdF) and two defrost modes: timed or controlled by the evaporator's probe (P2P).

3.3 AUXILIARY RELAY CONFIGURATION - TERM.5-6/7, PAR. OA1

The functioning of the auxiliary relay (terminals. 5-6/7) can be set by the **oA1** parameter, according to the kind of application. In the following paragraph the possible setting:

3.3.1 Light relay - oA1= Lig

With **oA1 = Lig**, the 5-6/7 relay is set as light. It is activated by key or when i1F = dor.

3.3.2 Alarm relay - oA1= AUS

There are 2 possibilities:

a. Activation via digital input (oA1 = AUS, i1F or i2F = AUS)

With **oA1 = AUS** and i2F or i1F = AUS the relay 5-6/7 is activated via digital input and remains ON until the digital input is activated or is silenced by pressing any key.

b. Auxiliary thermostat (es. anti-sweat heaters)

Parameters involved:

- ACH Type of regulation: heating/cooling;
- SAA Set point auxiliary relay
- SHy Differential for auxiliary relay
- ArP Probe for auxiliary relay
- Sdd Auxiliary output off during defrost

By means of these 5 parameters the functioning of the auxiliary relay can be set.

NOTE: Set **oA1 =AUS** and **ArP= nP** (no probe for auxiliary output).

In this case the relay 5-6/7 can be activated only by digital input with i1F or i2F = AUS.

3.3.3 On/off relay – oA1 = onF

In this case the relay is activated when the controller is turned on and de-activated when the controller is in stand-by mode.

3.3.4 Neutral zone regulation

With **oA1 = db** the relay 5-6/7 can control a heater element to perform a neutral zone action.

oA1 cut in = SET-HY

oA1 cut out = SET

3.3.5 Second compressor

With **oA1 = CP2**, the relay 5-6/7 operates as second compressor: it is activated in parallel with the relay of the first compressor, with a possible delay set in the **AC1** parameter. Both the relays are switched off at the same time.

3.3.6 Alarm relay

With **oA1 = ALR** the relay 5-6/7 operates as alarm relay. It is activated every time an alarm happens. Its status depends on the **tBA** parameter.

With "**tBA = y**", the relay is silenced by pressing any key.

With "**tBA = n**", the alarm relay remains on until the alarm condition recovers.

3.3.7 Night blind management during energy saving cycles

With **oA1 = HES**, the relay 5-6/7 operates to manage the night blind: the relay is energised when the energy saving cycle is activated, by digital input, frontal button or RTC (optional).

4. FRONT PANEL COMMANDS

4.1 XW20LR:STANDARD FRONTAL PANEL



4.2 XW20LR: STEEL FINISHING



4.1 XW20LRH



SET: To display target set point; in programming mode it selects a parameter or confirm an operation.

(DEF) To start a manual defrost.

(UP): To see the max. stored temperature; in programming mode it browses the parameter codes or increases the displayed value.

(DOWN) To see the min stored temperature; in programming mode it browses the parameter codes or decreases the displayed value.

To switch the instrument off, if onF = oFF.

To switch the light, if oA1 = Lig.

KEY COMBINATIONS:

+ To lock & unlock the keyboard.

SET + To enter in programming mode.

SET + To return to the room temperature display.

4.2 USE OF LEDS

Each LED function is described in the following table.

| LED | MODE | FUNCTION |
|------------|----------|--------------------------------|
| | ON | Compressor enabled |
| | Flashing | Anti-short cycle delay enabled |
| | ON | Defrost enabled |
| | Flashing | Drip time in progress |
| | ON | An alarm is occurring |
| | ON | Continuous cycle is running |
| | ON | Energy saving enabled |
| | ON | Light on |
| ALX | ON | Auxiliary relay on |
| °C | ON | Measurement unit |
| °C | Flashing | Programming phase |

5. MAX & MIN TEMPERATURE MEMORIZATION

5.1 HOW TO SEE THE MIN TEMPERATURE

1. Press and release the **▼** key.
2. The "Lo" message will be displayed followed by the minimum temperature recorded.
3. By pressing the **▼** key again or by waiting 5s the normal display will be restored.

5.2 HOW TO SEE THE MAX TEMPERATURE

1. Press and release the **▲** key.
2. The "Hi" message will be displayed followed by the maximum temperature recorded.
3. By pressing the **▲** key again or by waiting 5s the normal display will be restored.

5.3 HOW TO RESET THE MAX AND MIN TEMPERATURE RECORDED

1. Hold press the SET key for more than 3s, while the max. or min temperature is displayed. (rSt message will be displayed)
2. To confirm the operation the "rSt" message starts blinking and the normal temperature will be displayed.

6. MAIN FUNCTIONS

6.1 TO SET THE CURRENT TIME AND DAY (ONLY FOR INSTRUMENTS WITH RTC)

When the instrument is switched on, it's necessary to program the time and day.

1. Enter the Pr1 programming menu, by pushing the SET + **▼** keys for 3s.
2. The rtc parameter is displayed. Push the SET key to enter the real time clock menu.
3. The Hur (hour) parameter is displayed.
4. Push the SET and set current hour by the UP and Down keys, then push SET to confirm the value..
5. Repeat the same operations on the Min (minutes) and dAy (day) parameters.

To exit: Push SET+UP keys or wait for 15 sec without pushing any keys.

6.2 HOW TO SEE THE SET POINT

1. Push and immediately release the SET key: the display will show the Set point value;

2. Push and immediately release the SET key or wait for 5 seconds to display the probe value again.

6.3 HOW TO CHANGE THE SET POINT

1. Push the SET key for more than 2 seconds to change the Set point value;
2. The value of the set point will be displayed and the "°C" LED starts blinking;
3. To change the Set value push the **▲** or **▼** arrows within 10s.
4. To memorise the new set point value push the SET key again or wait 10s.

6.4 HOW TO START A MANUAL DEFROST

Push the DEF key for more than 2 seconds and a manual defrost will start.

6.5 HOW TO CHANGE A PARAMETER VALUE

To change the parameter's value operate as follows:

1. Enter the Programming mode by pressing the Set + **▼** keys for 3s (the "°C" LED starts blinking).
2. Select the required parameter. Press the "SET" key to display its value
3. Use "UP" or "DOWN" to change its value.
4. Press "SET" to store the new value and move to the following parameter.

To exit: Press SET + UP or wait 15s without pressing a key.

NOTE: the set value is stored even when the procedure is exited by waiting the time-out to expire.

6.6 THE HIDDEN MENU

The hidden menu Includes all the parameters of the instrument.

6.6.1 HOW TO ENTER THE HIDDEN MENU

1. Enter the Programming mode by pressing the Set + **▼** keys for 3s (the "°C" LED starts blinking).
2. Released the keys, then push again the Set+ **▼** keys for more than 7s. The Pr2 label will be displayed immediately followed from the HY parameter.

NOW YOU ARE IN THE HIDDEN MENU.

3. Select the required parameter.
4. Press the "SET" key to display its value
5. Use **▲** or **▼** to change its value.
6. Press "SET" to store the new value and move to the following parameter.

To exit: Press SET + **▲** or wait 15s without pressing a key.

NOTE1: if none parameter is present in Pr1, after 3s the "noP" message is displayed. Keep the keys pushed till the Pr2 message is displayed.

NOTE2: the set value is stored even when the procedure is exited by waiting the time-out to expire.

6.6.2 HOW TO MOVE A PARAMETER FROM THE HIDDEN MENU TO THE FIRST LEVEL AND VICEVERSA.

Each parameter present in the HIDDEN MENU can be removed or put into "THE FIRST LEVEL" (user level) by pressing "SET + **▼**".

In HIDDEN MENU when a parameter is present in First Level the decimal point is on.

6.7 HOW TO LOCK THE KEYBOARD

1. Keep pressed for more than 3 s the UP + DOWN keys.
2. The "POF" message will be displayed and the keyboard will be locked. At this point it will be possible only to see the set point or the MAX o Min temperature stored
3. If a key is pressed more than 3s the "POF" message will be displayed.

6.8 TO UNLOCK THE KEYBOARD

Keep pressed together for more than 3s the **▲** and **▼** keys, till the "Pon" message will be displayed.

6.9 THE CONTINUOUS CYCLE

When defrost is not in progress, it can be activated by holding the "**▲**" key pressed for about 3 seconds. The compressor operates to maintain the "ccS" set point for the time set through the "CC" parameter. The cycle can be terminated before the end of the set time using the same activation key "**▲**" for 3 seconds.

6.10 THE ON/OFF FUNCTION

With "onF = offF", pushing the ON/OFF key, the instrument is switched off. The "OFF" message is displayed. In this configuration, the regulation is disabled.

To switch the instrument on, push again the ON/OFF key.

WARNING: Loads connected to the normally closed contacts of the relays are always supplied and under voltage, even if the instrument is in stand by mode.

7. PARAMETERS

rtc Real time clock menu (only for controller with RTC): to set the time and date and defrost start time.

REGULATION

- Hy Differential:** (0.1 + 25.5°C / 1+255 °F) Intervention differential for set point. Compressor Cut IN is Set point + differential (Hy). Compressor Cut OUT is when the temperature reaches the set point.
- LS Minimum set point:** (-50°C+SET/-58°F+SET): Sets the minimum value for the set point.
- US Maximum set point:** (SET+110°C/ SET+230°F). Set the maximum value for set point.
- Ot Thermostat probe calibration:** (-12.0+12.0°C; -120+120°F) allows to adjust possible offset of the thermostat probe.
- P2P Evaporator probe presence:** n= not present: the defrost stops by time; y= present: the defrost stops by temperature.
- OE Evaporator probe calibration:** (-12.0+12.0°C; -120+120°F). allows to adjust possible offset of the evaporator probe.
- P3P Third probe presence (P3):** n= not present., the terminals 13-14 operate as digital input.; y= present., the terminals 13-14 operate as third probe.
- O3 Third probe calibration (P3):** (-12.0+12.0°C; -120+120°F). allows to adjust possible offset of the third probe.
- OdS Outputs activation delay at start up:** (0+255min) This function is enabled at the initial start up of the instrument and inhibits any output activation for the period of time set in the parameter.
- AC Anti-short cycle delay:** (0+50 min) minimum interval between the compressor stop and the following restart.
- AC1 2nd compressor delay at start up (0+255s)** Used only if oA3 = cP2 Time interval between the switching on of the first compressor and the second one.
- rtr Percentage of the second and first probe for regulation (0+100; 100 = P1, 0 = P2):** it allows to set the regulation according to the percentage of the first and second probe, as for the following formula (rtr(P1-P2)/100 + P2).
- CCt Compressor ON time during continuous cycle:** (0.0+24.0h; res. 10min) Allows to set the length of the continuous cycle: compressor stays on without interruption for the CCt time. Can be used, for instance, when the room is filled with new products.
- CCS Set point for continuous cycle:** (-50+150°C) it sets the set point used during the continuous cycle.
- CO_n Compressor ON time with faulty probe:** (0+255 min) time during which the compressor is active in case of faulty thermostat probe. With CO_n=0 compressor is always OFF.
- CO_F Compressor OFF time with faulty probe:** (0+255 min) time during which the compressor is OFF in case of faulty thermostat probe. With CO_F=0 compressor is always active.
- CH Type of action:** CL = cooling; Ht = heating.

DISPLAY

- CF Temperature measurement unit:** °C=Celsius; °F=Fahrenheit. **WARNING:** When the measurement unit is changed the SET point and the values of the parameters Hy, LS, US, Ot, ALU and ALL have to be checked and modified if necessary).
- rES Resolution (for °C):** (in = 1°C; dE = 0.1 °C) allows decimal point display.
- Lod Instrument display:** (P1; P2, P3, P4, SET, dtr): it selects which probe is displayed by the instrument: P1 = Thermostat probe; P2 = Evaporator probe; P3 = Third probe(only for model with this option enabled); P4 = Fourth probe, SET = set point; dtr = percentage of visualization.
- rEd X-REP display (optional):** (P1; P2, P3, P4, SET, dtr): it selects which probe is displayed by X-REP: P1 = Thermostat probe; P2 = Evaporator probe; P3 = Third probe(only for model with this option enabled); P4 = Fourth probe, SET = set point; dtr = percentage of visualization.
- dLy Display delay:** (0 +20.0m; resul. 10s) when the temperature increases, the display is updated of 1 °C/1°F after this time.
- dtr Percentage of the second and first probe for visualization when Lod = dtr (0+100; 100 = P1, 0 = P2):** if Lod = dtr it allows to set the visualization according to the percentage of the first and second probe, as for the following formula (dtr(P1-P2)/100 + P2).

DEFROST

EdF Defrost mode (only for controller with RTC):
rtc = Real Time Clock mode. Defrost time follows Ld1+Ld6 parameters on workdays and Sd1+Sd6 on holidays.

in = interval mode. The defrost starts when the time "ldf" is expired.

dFP Probe selection for defrost termination: nP = no probe; P1 = thermostat probe; P2 = evaporator probe; P3 = configurable probe; P4 = fourth probe.

dTE Defrost termination temperature: (-50+50 °C/ -58+122°F) (Enabled only when EdF=Pb) sets the temperature measured by the evaporator probe, which causes the end of defrost.

ldf Interval between defrost cycles: (0+120h) Determines the time interval between the beginning of two defrost cycles.

MdF (Maximum) length for defrost: (0+255min) When P2P = n, (not evaporator probe: timed defrost) it sets the defrost duration, when P2P = y (defrost end based on temperature) it sets the maximum length for defrost.

dFd Temperature displayed during defrost: (rt = real temperature; it = temperature at defrost start; SEt = set point; dEF = "dEF" label)

dAd MAX display delay after defrost: (0+120min). Sets the maximum time between the end of defrost and the restarting of the real room temperature display.

AUXILIARY THERMOSTAT CONFIGURATION (terms. 5-6/7) – OA1 = AUS

ACH Kind of regulation for auxiliary relay: Ht = heating; CL = cooling

SAA Set Point for auxiliary relay: (-50,0+110,0°C; -58+230°F) it defines the room temperature set point to switch auxiliary relay.

SHy Differential for auxiliary output: (0,1 + 25,5°C / 1+25,5°F) Intervention differential for auxiliary output set point.

With ACH = cL AUX Cut in is SAA + SHy; . AUX Cut out is SAA

With ACH = Ht AUX Cut in is SAA - SHy; . AUX Cut out is SAA

ArP Probe selection for auxiliary: nP = no probe, the auxiliary relay is switched only by button; P1 = Probe 1 (Thermostat probe); P2 = Probe 2 (evaporator probe); P3 = Probe 3 (display probe); P4 = Probe 4 fourth probe.

Sdd Auxiliary relay off during defrost: n = the auxiliary relay 5-6/7 operates during defrost. y = the auxiliary relay 5-6/7 is switched off during defrost.

ALARMS

ALP Probe selection for alarm: P1 = Probe 1; P2 = Probe 2; P3 = Probe 3; P4 = Fourth probe.

ALC Temperature alarms configuration: (Ab; rE) Ab= absolute temperature: alarm temperature is given by the ALL or ALU values. rE = temperature alarms are referred to the set point. Temperature alarm is enabled when the temperature exceeds the "SET+ALU" or "SET-ALL" values.

ALU MAXIMUM temperature alarm: (SET+110°C; SET+230°F) when this temperature is reached the alarm is enabled, after the "ALD" delay time.

ALL Minimum temperature alarm: (-50,0 + SET °C; -58+230°F) when this temperature is reached the alarm is enabled, after the "ALD" delay time.

AFH Differential for temperature alarm recovery: (0,1+25,5°C; 1+45°F) Intervention differential for recovery of temperature alarm.

ALd Temperature alarm delay: (0+255 min) time interval between the detection of an alarm condition and alarm signalling.

dAO Exclusion of temperature alarm at start-up: (from 0.0 min to 23.5h) time interval between the detection of the temperature alarm condition after instrument power on and alarm signalling.

CONDENSER TEMPERATURE ALARM

AP2 Probe selection for temperature alarm of condenser: nP = no probe; P1 = thermostat probe; P2 = defrost termination probe; P3 = configurable probe; P4 = fourth probe.

AL2 Low temperature alarm of condenser: (-55+150°C) when this temperature is reached the LA2 alarm is signalled, possibly after the Ad2 delay.

Au2 High temperature alarm of condenser: (-55+150°C) when this temperature is reached the HA2 alarm is signalled, possibly after the Ad2 delay.

AH2 Differential for temperature condenser alarm recovery: (0,1+25,5°C; 1+45°F)

Ad2 Condenser temperature alarm delay: (0+255 min) time interval between the detection of the condenser alarm condition and alarm signalling.

da2 Condenser temperature alarm exclusion at start up: (from 0.0 min to 23.5h, res. 10min)

bLL Compressor off with low temperature alarm of condenser: n = no: compressor keeps on working; Y = yes, compressor is switched off till the alarm is present, in any case regulation restarts after AC time at minimum.

AC2 Compressor off with high temperature alarm of condenser: n = no: compressor keeps on working; Y = yes, compressor is switched off till the alarm is present, in any case regulation restarts after AC time at minimum.

AUXILIARY RELAY

tbA Alarm relay silencing (with oA1 = ALr):

n = silencing disabled: alarm relay stays on till alarm condition lasts,

y = silencing enabled: alarm relay is switched OFF by pressing a key during an alarm

oA1 Second relay configuration (5-6/7): dEF, FAn: do not select it!. ALr: alarm; Lig: light; AuS: Auxiliary relay; onF: always on with instrument on; db= neutral zone; cP2 = second compressor; dF2: do not select it!; HES: night blind

AoP Alarm relay polarity: it set if the alarm relay is open or closed when an alarm happens. CL = terminals 1-4 closed during an alarm; oP = terminals 1-4 open during an alarm

DIGITAL INPUTS

i1P Digital input polarity (13-14): oP: the digital input is activated by opening the contact; CL: the digital input is activated by closing the contact.

i1F Digital input configuration (13-14): EAL= external alarm: "EA" message is displayed; bAL= serious alarm "CA" message is displayed. PAL= pressure switch alarm, "CA" message is displayed; dor= door switch function; dEF= activation of a defrost cycle; AUS= auxiliary relay for oA1 or oA4=AUS; Htr= kind of action inversion (cooling – heating); FAn= not set it; ES= Energy saving; HdF = Holiday defrost (enable only with RTC); onF = to switch the controller off.

did (0+255 min) with i1F= EAL or i1F = bAL digital input alarm delay (13-14): delay between the detection of the external alarm condition and its signalling.

with i1F= dor: door open signalling delay

with i1F= PAL: time for pressure switch function: time interval to calculate the number of the pressure switch activation.

i2P 2nd digital input polarity (13-19): oP: the digital input is activated by opening the contact; CL: the digital input is activated by closing the contact.

i2F 2nd digital input configuration (13-19): EAL= external alarm: "EA" message is displayed; bAL= serious alarm "CA" message is displayed. PAL= pressure switch alarm, "CA" message is displayed; dor= door switch function; dEF= activation of a defrost cycle; AUS=not enabled; Htr= kind of action inversion (cooling – heating); FAn= not set it; ES= Energy saving; HdF = Holiday defrost (enable only with RTC); onF = to switch the controller off.

d2d (0+255 min) with i2F= EAL or i2F= bAL 2nd digital input alarm delay (13-19): delay between the detection of the external alarm condition and its signalling.

with i2F= dor: door open signalling delay

with i2F= PAL: time for pressure switch function: time interval to calculate the number of the pressure switch activation.

nPS Pressure switch number: (0 +15) Number of activation of the pressure switch, during the "did" interval, before signalling the alarm event (i2F= PAL).

If the nPS activation in the did time is reached, switch off and on the instrument to restart normal regulation.

odc Compressor status when open door: no, Fan = normal; CPr, F_C = Compressor OFF.

rrd Outputs restart after doA alarm: no= outputs not affected by the doA alarm; yES = outputs restart with the doA alarm.

HES Temperature increase during the Energy Saving cycle: (-30,0°C+30,0°C) it sets the increasing value of the set point during the Energy Saving cycle.

TO SET CURRENT TIME AND WEEKLY HOLIDAYS (ONLY FOR MODELS WITH RTC)

Hur Current hour (0 + 23 h)

Min Current minute (0 + 59min)

dAY Current day (Sun + SAT)

Hd1 First weekly holiday (Sun + nu) Set the first day of the week which follows the holiday times.

Hd2 Second weekly holiday (Sun + nu) Set the second day of the week which follows the holiday times.

N.B. Hd1,Hd2 can be set also as "nu" value (Not Used).

TO SET ENERGY SAVING TIMES (ONLY FOR MODELS WITH RTC)

ILE Energy Saving cycle start during workdays: (0 + 23h 50 min.) During the Energy Saving cycle the set point is increased by the value in HES so that the operation set point is SET + HES.

dLE Energy Saving cycle length during workdays: (0 + 24h 00 min.) Sets the duration of the Energy Saving cycle on workdays.

ISE Energy Saving cycle start on holidays. (0 + 23h 50 min.)

dSE Energy Saving cycle length on holidays (0 + 24h 00 min.)

TO SET DEFROST TIMES (ONLY FOR MODELS WITH RTC)

Ld1+Ld6 Workday defrost start (0 + 23h 50 min.) These parameters set the beginning of the 6 programmable defrost cycles during workdays. Ex. When Ld2 = 12.4 the second defrost starts at 12.40 during workdays.

Sd1+Sd6 Holiday defrost start (0 + 23h 50 min.) These parameters set the beginning of the 6 programmable defrost cycles on holidays. Ex. When Sd2 = 3.4 the second defrost starts at 3.40 on holidays.

N.B. :To disable a defrost cycle set it to "nu"(not used). Ex. If Ld6=nu ; the sixth defrost cycle is disabled

OTHER

Adr Serial address (1+244): Identifies the instrument address when connected to a ModBUS compatible monitoring system.

PbC Type of probe: it allows to set the kind of probe used by the instrument: PTC = PTC probe, ntc = NTC probe.

onF on/off key enabling: nu = disabled; oFF = enabled; ES = not set it.

dP1 Thermostat probe display

dP2 Evaporator probe display

dP3 Third probe display- optional.

rSE Real set point: it shows the set point used during the energy saving cycle or during the continuous cycle.

rEL Software release for internal use.

Ptb Parameter table code: readable only.

8. DIGITAL INPUTS

The first digital input is enabled with P3P = n.

With P3P = n and i1F = i2F the second digital input is disabled

The free voltage digital inputs are programmable by the "i1F" and i2F parameters.

8.1 GENERIC ALARM (i1F or i2F = EAL)

As soon as the digital input is activated the unit will wait for "did" time delay before signalling the "EAL" alarm message. The outputs status don't change. The alarm stops just after the digital input is de-activated.

8.2 SERIOUS ALARM MODE (i1F or i2F = bAL)

When the digital input is activated, the unit will wait for "did" delay before signalling the "CA" alarm message. The relay outputs are switched OFF. The alarm will stop as soon as the digital input is de-activated.

8.3 PRESSURE SWITCH (i1F or i2F = PAL)

If during the interval time set by "did" parameter, the pressure switch has reached the number of activation of the "nPS" parameter, the "CA" pressure alarm message will be displayed. The compressor and the regulation are stopped. When the digital input is ON the compressor is always OFF. If the nPS activation in the did time is reached, switch off and on the instrument to restart normal regulation.

8.4 DOOR SWITCH INPUT (i1F or i2F = dor)

It signals the door status and the corresponding relay output status through the "odc" parameter: no, Fan = normal (any change); CPr, F_C = Compressor OFF.

Since the door is opened, after the delay time set through parameter "did", the door alarm is enabled, the display shows the message "dA" and the regulation restarts it rtr = yES. The alarm stops as soon as the external digital input is disabled again. With the door open, the high and low temperature alarms are disabled.

8.5 START DEFROST (i1F or i2F = dEF)

It starts a defrost if there are the right conditions. After the defrost is finished, the normal regulation will restart only if the digital input is disabled otherwise the instrument will wait until the "MdF" safety time is expired.

8.6 SWITCH THE AUXILIARY RELAY (i1F or i2F = AUS)

With oA1 = AUS the digital input switched the status of the auxiliary relay

8.7 ENERGY SAVING (i1F or i2F = ES)

The Energy Saving function allows to change the set point value as the result of the SET+ HES (parameter) sum. This function is enabled until the digital input is activated.

8.8 HOLIDAY DEFROST (i1F or i2F = HDF) –ONLY FOR MODELS WITH RTC

This function enabled the holiday defrost setting.

8.9 ON OFF FUNCTION (i1F or i2F = ONF)

To switch the controller on and off.

8.10 DIGITAL INPUTS POLARITY

The digital input polarity depends on the "i1P" and "i2P" parameters.

i1P or i2P =CL: the input is activated by closing the contact.

i1P or i2P=OP: the input is activated by opening the contact

9. TTL SERIAL LINE – FOR MONITORING SYSTEMS

The TTL serial line, available through the HOT KEY connector, allows by means of the external TTL/RS485 converter, XJ485-CX, to connect the instrument to a monitoring system ModBUS-RTU compatible such as the X-WEB500/3000/300.

10. X-REP OUTPUT – OPTIONAL

As optional, an X-REP can be connected to the instrument, trough the HOY KEY connector. The X-REP output EXCLUDES the serial connection.



To connect the X-REP to the instrument the following connectors must be used CAB-51F(1m), CAB-52F(2m), CAB-55F(5m).

11. INSTALLATION AND MOUNTING

The controller shall be mounted on vertical panel, in a 150x31 mm hole, and fixed using two screws \varnothing 3 x 2mm (only for XW20LR).

XW20LR: to obtain an IP65 protection grade use the front panel rubber gasket (mod. RG-L). The temperature range allowed for correct operation is 0 - 60 °C. Avoid places subject to strong vibrations, corrosive gases, excessive dirt or humidity. The same recommendations apply to probes. Let the air circulate by the cooling holes.

11.1 CUT OUT

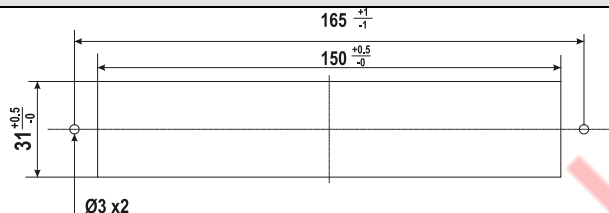

XW20LRH: the holes are not required

11.2 STEEL FINISHING MOUNTING

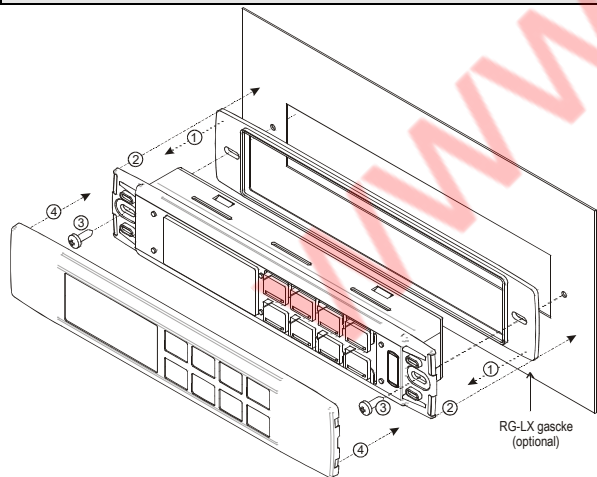

12. ELECTRICAL CONNECTIONS

The instruments are provided with screw terminal block to connect cables with a cross section up to 2,5 mm² for the digital and analogue inputs. Relays and power supply have a Faston connection (6,3mm). Heat-resistant cables have to be used. Before connecting cables make sure the power supply complies with the instrument's requirements. Separate the probe cables from the power supply cables, from the outputs and the power connections. Do not exceed the maximum current allowed on each relay, in case of heavier loads use a suitable external relay.
N.B. Maximum current allowed for all the loads is 20A.

12.1 PROBE CONNECTION

The probes shall be mounted with the bulb upwards to prevent damages due to casual liquid infiltration. It is recommended to place the thermostat probe away from air streams to correctly measure the average room temperature. Place the defrost termination probe among the evaporator fins in the coldest place, where most ice is formed, far from heaters or from the warmest place during defrost, to prevent premature defrost termination.

13. HOW TO USE THE HOT KEY

13.1 HOW TO PROGRAM A HOT KEY FROM THE INSTRUMENT (UPLOAD)

1. Program one controller with the front keypad.
2. When the controller is ON, insert the "Hot key" and push \blacktriangle key; the "uPL" message appears followed a by flashing "End"
3. Push "SET" key and the End will stop flashing.
4. Turn OFF the instrument remove the "Hot Key", then turn it ON again.

NOTE: the "Err" message is displayed for failed programming. In this case push again \blacktriangle key if you want to restart the upload again or remove the "Hot key" to abort the operation.

13.2 HOW TO PROGRAM AN INSTRUMENT USING A HOT KEY (DOWNLOAD)

1. Turn OFF the instrument.
2. Insert a programmed "Hot Key" into the 5 PIN receptacle and then turn the Controller ON.
3. Automatically the parameter list of the "Hot Key" is downloaded into the Controller memory, the "doL" message is blinking followed a by flashing "End".
4. After 10 seconds the instrument will restart working with the new parameters.
5. Remove the "Hot Key".

NOTE the message "Err" is displayed for failed programming. In this case turn the unit off and then on if you want to restart the download again or remove the "Hot key" to abort the operation.

14. ALARM SIGNALS

| Message | Cause | Outputs |
|---------|----------------------------------|--|
| "P1" | Room probe failure | Compressor output acc. to par. "Con" and "COF" |
| "P2" | Second probe failure | Defrost end is timed |
| "P3" | Third probe failure | Outputs unchanged |
| "HA" | Maximum temperature alarm | Outputs unchanged. |
| "LA" | Minimum temperature alarm | Outputs unchanged. |
| "HA2" | Condenser high temperature | It depends on the "Ac2" parameter |
| "LA2" | Condenser low temperature | It depends on the "bLL" parameter |
| "dA" | Door open | Loads according to the "odC" parameter |
| "EA" | External alarm | Output unchanged. |
| "CA" | Serious external alarm (i1F=bAL) | All outputs OFF. |
| "CA" | Pressure switch alarm (i1F=PAL) | All outputs OFF |
| "rtc" | Real time clock alarm | Alarm output ON; Other outputs unchanged; Defrosts according to par. "IdF" Set real time clock has to be set |
| rtF | Real time clock board failure | Alarm output ON; Other outputs unchanged; Defrosts according to par. "IdF" Contact the service |

14.1 ALARM RECOVERY

Probe alarms "P1", "P2" and "P4" start some seconds after the fault in the related probe; they automatically stop some seconds after the probe restarts normal operation. Check connections before replacing the probe.

Temperature alarms "HA", "LA", "HA2" and "LA2" automatically stop as soon as the temperature returns to normal values.

Alarms "EA" and "CA" (with i1F=bAL) recover as soon as the digital input is disabled.

Alarm "CA" (with i1F=PAL) recovers only by switching off and on the instrument.

Real time clock alarm rtC, it stops as soon as the correct hour and day are set.

Real time clock alarm rtF, the clock board has to be replaced. Contact the service.

14.2 OTHER MESSAGES

| | |
|-----|--|
| Pon | Keyboard unlocked. |
| PoF | Keyboard locked |
| noP | In programming mode: none parameter is present in Pr1 On the display or in dP2, dP3, dP4: the selected probe is nor enabled |

15. TECHNICAL DATA

Housing: self extinguishing ABS.

Case: facia 38x185 mm; depth 40mm

Mounting : panel mounting in a 150x31 mm panel cut-out.

Only for XW20LR two screws, \varnothing 3 x 2mm, distance between the holes 165mm

Protection: IP20; Frontal protection: IP65 with frontal gasket mod RG-L or RG-LX.

Connections: Screw terminal block \leq 2,5 mm² heat-resistant wiring and 6,3mm Faston

Power supply: 230Vac or. 110Vac \pm 10%, 50/60Hz.

Power absorption: 7VA max.

Display: 3 digits, red LED, 14,2 mm high.

Inputs: Up to 3 NTC or PTC probes.

Digital inputs: free voltage

Relay outputs: **Total current on loads MAX. 20A**

compressor: relay SPST 20(8) A, 250Vac

light: relay SPST 8A, 250Vac

Other output : buzzer (optional)

Serial output : TTL standard; Communication protocol: Modbus - RTU

Data storing: on the non-volatile memory (EEPROM).

Internal clock back-up: 24 hours (only for model with RTC)

Kind of action: 1B; Pollution grade: normal; Software class: A.;

Over voltage Category: II

Operating temperature: 0+60 °C; Storage temperature: -30+85 °C.

Relative humidity: 20-85% (no condensing)

Measuring and regulation range: NTC probe: -40+110°C (-40+230°F);

PTC probe: -50+150°C (-58+302°F)

Resolution: 0,1 °C or 1 °F (selectable); Accuracy (ambient temp. 25°C): \pm 0,7 °C \pm 1 digit

16. CONNECTIONS

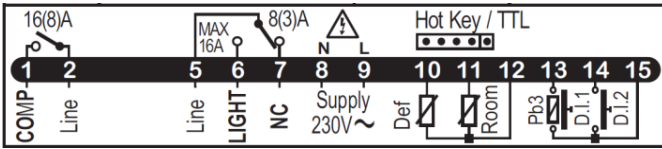

Models at 120Vac or 24Vac: connect to terminals 8-9.

NOTE: on models with X-REP option, connect the X-REP to the HOT KEY receptacle

17. DEFAULT SETTING VALUES

| Label | Name | Range | Value | Level |
|-------|---|--|-------|-------|
| Set | Set point | LS - US | 3.0 | - - - |
| rtc* | Real time clock menu | | - | Pr1 |
| Hy | Differential | (0,1°C + 25,5°C) | 2.0 | Pr1 |
| LS | Minimum set point | (-55,0°C + SET) | -50.0 | Pr2 |
| US | Maximum set point | (SET + 150,0°C) | 110 | Pr2 |
| Ot | P1 probe calibration | (-12,0°C + 12,0°C) | 0.0 | Pr1 |
| P2P | P2 probe presence | n - Y | n | Pr1 |
| OE | P2 probe calibration | (-12,0°C + 12,0°C) | 0.0 | Pr2 |
| P3P | P3 probe presence | n - Y | n | Pr2 |
| O3 | P3 probe calibration | (-12,0°C + 12,0°C) | 0 | Pr2 |
| odS | Outputs delay at start up | 0 + 255 (min.) | 0 | Pr2 |
| AC | Anti-short cycle delay | 0 + 50 (min.) | 1 | Pr1 |
| Ac1 | Second compressor start delay | 0 + 255 (sec.) | 5 | Pr2 |
| rtr | P1-P2 percentage for regulation | 0 + 100 (100=P1, 0=P2) | 100 | Pr2 |
| CCt | Continuous cycle duration | 0 + 24H0(144) | 0.0 | Pr2 |
| CCS | Set point for continuous cycle | (-55,0°C + 150,0°C) | 3.0 | Pr2 |
| CO n | Compressor ON time with faulty probe | 0 + 255 (min.) | 15 | Pr2 |
| COF | Compressor OFF time with faulty probe | 0 + 255 (min.) | 30 | Pr2 |
| CH | Kind of action | cL, Ht | cL | Pr1 |
| CF | Temperature measurement unit | °C - °F | °C | Pr2 |
| rES | Resolution | dE - in | dE | Pr1 |
| Lod | Probe displayed | P1 - P2 - P3 - P4 - SET - dtr | P1 | Pr2 |
| rEd2 | X-REP display | P1 - P2 - P3 - P4 - SET - dtr | P1 | Pr2 |
| dLy | Display temperature delay | 0 + 20.0min (ris. 10 sec.) | 0.0 | Pr2 |
| dtr | P1-P2 percentage for display | 1 + 99 | 50 | Pr2 |
| EdF* | Kind of interval for defrost | rtc+in | in | Pr2 |
| dFP | Probe selection for defrost termination | nP - P1 - P2 - P3 - P4 | nP | Pr2 |
| dTE | Defrost termination temperature | (-55,0°C + 50,0°C) | 3.0 | Pr1 |
| IdF | Interval between defrost cycles | 0 + 120 (h) | 8 | Pr1 |
| MdF | (Maximum) length for defrost | 0 + 255 (min.) | 20 | Pr1 |
| dFd | Displaying during defrost | rt - it - SET - dEF | it | Pr2 |
| dAd | MAX display delay after defrost | 0 + 255 (min.) | 30 | Pr2 |
| ACH | Kind of action for auxiliary relay | CL - Ht | cL | Pr2 |
| SAA | Set Point for auxiliary relay | (-55,0°C + 150,0°C) | 0,0 | Pr2 |
| SHy | Differential for auxiliary relay | (0,1°C + 25,5°C) | 2,0 | Pr2 |
| ArP | Probe selection for auxiliary relay | nP - P1 - P2 - P3 - P4 | nP | Pr2 |
| Sdd | Auxiliary relay operating during defrost | n - Y | n | Pr2 |
| ALP | Alarm probe selection | nP - P1 - P2 - P3 - P4 | P1 | Pr2 |
| ALc | Temperat. alarms configuration | rE - Ab | Ab | Pr2 |
| ALU | MAXIMUM temperature alarm | ALc=rE: 0.0+ 50.0°C ALc=Ab: ALL+150°C | 110,0 | Pr1 |
| ALL | Minimum temperature alarm | ALc = rE: 0.0+50.0°C; ALc=Ab: -55°C+ALU | -50,0 | Pr1 |
| AFH | Differential for temperat. alarm recovery | (0,1°C + 25,5°C) | 2,0 | Pr2 |
| ALd | Temperature alarm delay | 0 + 255 (min.) | 15 | Pr2 |
| dAO | Delay of temperature alarm at start up | 0 + 24.0 h ris. 10min | 1,3 | Pr2 |
| AP2 | Probe for temperat. alarm of condenser | nP - P1 - P2 - P3 - P4 | nP | Pr2 |
| AL2 | Condenser for low temperat. alarm | (-55,0°C + 150,0°C) | -40 | Pr2 |
| AU2 | Condenser for high temperat. alarm | (-55,0°C + 150,0°C) | 110 | Pr2 |
| AH2 | Differ. for condenser temp. alar. recovery | (0,1°C + 25,5°C) | 5 | Pr2 |
| Ad2 | Condenser temperature alarm delay | 0 + 255 (min.) | 15 | Pr2 |
| dA2 | Delay of cond. temper. alarm at start up | 0 + 24H0(144) | 1,3 | Pr2 |
| bLL | Compr. off for condenser low temperature alarm | n - Y | n | Pr2 |
| AC2 | Compr. off for condenser high temperature alarm | n - Y | n | Pr2 |
| tbA | Alarm relay disabling | n - Y | y | Pr2 |
| oA1 | Second relay configuration | dEF - FAn - ALr - LiG - AUS - OnF - db - CP2 - dF2 - HES | Lig | Pr2 |
| AoP | Alarm relay polarity | OP - CL | cL | Pr2 |
| i1P | Digital input polarity | OP - CL | cL | Pr1 |
| i1F | Digital input 1 configuration | EAL - bAL - PAL - dor - dEF - AUS - Htr - FAn - ES-HdF - onF | dor | Pr1 |
| did | Digital input alarm delay | 0 + 255 (min.) | 15 | Pr1 |
| i2P | Digital input polarity | OP - CL | cL | Pr2 |
| i2F | Digital input configuration | EAL - bAL - PAL - dor - dEF - AUS - Htr - FAn - ES-HdF - onF | EAL | Pr2 |
| d2d | Digital input alarm delay | 0 + 255 (min.) | 5 | Pr2 |
| Nps | Number of activation of pressure switch | 0 + 15 | 15 | Pr2 |
| odc | Compress status when open door | no - FAn - CPr - F-C | F-c | Pr2 |
| rrd | Regulation restart with door open alarm | n - Y | y | Pr2 |
| HES | Differential for Energy Saving | (-30°C + 30°C) | 0 | Pr2 |
| Hur* | Current hour | Read only | - | rtc |
| Min* | Current minute | Read only | - | rtc |

| Label | Name | Range | Value | Level |
|-------|--|----------------|-------|-------|
| dAY* | Current day | Read only | - | rtc |
| Hd1* | First weekly holiday | Sun + SAT - nu | nu | rtc |
| Hd2* | Second weekly holiday | Sun + SAT - nu | nu | rtc |
| ILE* | Energy Saving cycle start during workdays | 0 + 23h5 | 0 | rtc |
| dLE* | Energy Saving cycle length during workdays | 0 + 24h0 | 0 | rtc |
| ISE* | Energy Saving cycle start on holidays | 0 + 23h5 | 0 | rtc |
| dSE* | Energy Saving cycle length on holidays | 0 + 24h0 | 0 | rtc |
| Ld1* | 1 st workdays defrost start | 0 + 23H5;- nu | 6.0 | rtc |
| Ld2* | 2 nd workdays defrost start | 0 + 23H5;- nu | 13.0 | rtc |
| Ld3* | 3 rd workdays defrost start | 0 + 23H5;- nu | 21.0 | rtc |
| Ld4* | 4 th workdays defrost start | 0 + 23H5;- nu | 0.0 | rtc |
| Ld5* | 5 th workdays defrost start | 0 + 23H5;- nu | 0.0 | rtc |
| Ld6* | 6 th workdays defrost start | 0 + 23H5;- nu | 0.0 | rtc |
| Sd1* | 1 st holiday defrost start | 0 + 23H5;- nu | 6.0 | rtc |
| Sd2* | 2 nd holiday defrost start | 0 + 23H5;- nu | 13.0 | rtc |
| Sd3* | 3 rd holiday defrost start | 0 + 23H5;- nu | 21.0 | rtc |
| Sd4* | 4 th holiday defrost start | 0 + 23H5;- nu | 0.0 | rtc |
| Sd5* | 5 th holiday defrost start | 0 + 23H5;- nu | 0.0 | rtc |
| Sd6* | 6 th holiday defrost start | 0 + 23H5;- nu | 0.0 | rtc |
| Adr | Serial address | 1 + 247 | 1 | Pr2 |
| PbC | Kind of probe | PTC - nTC | ntc | Pr2 |
| onF | on/off key enabling | nu - OFF - ES | oFF | Pr2 |
| dP1 | Room probe display | Probe value | - | Pr2 |
| dP2 | Evaporator probe display | Probe value | - | Pr2 |
| dP3 | Third probe display | Probe value | - | Pr2 |
| rSE | Real set point | Read only | - | Pr2 |
| rEL | Software release | Read only | 1.8 | Pr2 |
| Ptb | Map code | Read only | - | Pr2 |

2 Only for model with X-REP output
* Only for model with real time clock

Digital controller with defrost, fans and auxiliary relay management
XW60LR –XW60LRH

1. GENERAL WARNING

1.1 PLEASE READ BEFORE USING THIS MANUAL

- This manual is part of the product and should be kept near the instrument for easy and quick reference.
- The instrument shall not be used for purposes different from those described hereunder. It cannot be used as a safety device.
- Check the application limits before proceeding.
- Dixell Srl reserves the right to change the composition of its products, even without notice, ensuring the same and unchanged functionality.

1.2 SAFETY PRECAUTIONS

- Check the supply voltage is correct before connecting the instrument.
- Do not expose to water or moisture: use the controller only within the operating limits avoiding sudden temperature changes with high atmospheric humidity to prevent formation of condensation
- Warning: disconnect all electrical connections before any kind of maintenance.
- Fit the probe where it is not accessible by the End User. The instrument must not be opened.
- In case of failure or faulty operation send the instrument back to the distributor or to "Dixell S.r.l." (see address) with a detailed description of the fault.
- Consider the maximum current which can be applied to each relay (see Technical Data).
- Ensure that the wires for probes, loads and the power supply are separated and far enough from each other, without crossing or intertwining.
- In case of applications in industrial environments, the use of mains filters (our mod. FT1) in parallel with inductive loads could be useful.
- Dixell Srl reserves the right to change the composition of its products, even without notice, ensuring the same and unchanged functionality.

2. GENERAL DESCRIPTION

Models **XW60LR, XW60LRH**, format 38x185mm, are microprocessor based controller, suitable for applications on medium or low temperature ventilated refrigerating units. It has 4 relay outputs to control compressor, fan and defrost, which can be either electrical or reverse cycle (hot gas) It could be provided with a Real Time Clock which allows programming of up to 6 daily defrost cycles, divided into holidays and workdays. A "Day and Night" function with two different set points is fitted for energy saving. It is also provided with up to three NTC or PTC probe inputs, the first one for temperature control, the second one, to be located onto the evaporator, to control the defrost termination temperature and to managed the fan. Third probe can operates as digital input. The HOT KEY output allows to connect the unit, by means of the external module XJ485-CX, to a network line ModBUS-RTU compatible such as the **dixell** monitoring units of X-WEB family. It allows to program the controller by means the HOT KEY programming keyboard. The instrument is fully configurable through special parameters that can be easily programmed through the keyboard.

3. CONTROLLING LOADS

3.1 COMPRESSOR

The regulation is performed according to the temperature measured by the thermostat probe with a positive differential from the set point: if the temperature increases and reaches set point plus differential the compressor is started and then turned off when the temperature reaches the set point value again.

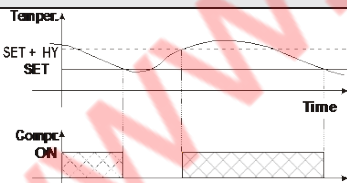

In case of fault in the thermostat probe the start and stop of the compressor are timed through parameters "CO_n" and "CO_F".

3.2 DEFROST

Two defrost modes are available through the "tdF" parameter: defrost through electrical heater (tdF = EL) and hot gas defrost (tdF = in).

The defrost interval depends on the presence of the RTC (optional). If the RTC is present is controlled by means of parameter "EdF":

- with EdF=in the defrost is made every "ldF" time – standard way for controller without RTC.
- with EdF = "rtc", the defrost is made in real time depending on the hours set in the parameters **Ld1..Ld6** on workdays and in **Sd1..Sd6** in holidays;

Other parameters are used to control defrost cycles: its maximum length (MdF) and two defrost modes: timed or controlled by the evaporator's probe (P2P).

At the end of defrost dripping time is started, its length is set in the Fdt parameter. With Fdt =0 the dripping time is disabled.

3.3 CONTROL OF EVAPORATOR FANS

The fan control mode is selected by means of the "FnC" parameter:

- FnC = C_n**: fans will switch ON and OFF with the compressor and **not run** during defrost;
 - FnC = o_n** fans will run even if the compressor is off, and not run during defrost;
- After defrost, there is a timed fan delay allowing for drip time, set by means of the "Fnd" parameter.
- FnC = C_Y** fans will switch ON and OFF with the compressor and **run** during defrost;
 - FnC = o_Y** fans will run continuously also during defrost

An additional parameter "FSt" provides the setting of temperature, detected by the evaporator probe, above which the fans are always OFF. This is used to make sure circulation of air only if his temperature is lower than set in "FSt".

3.3.1 Forced activation of fans

This function managed by the **Fct** parameter is designed to avoid short cycles of fans, that could happen when the controller is switched on or after a defrost, when the room air warms the evaporator. **Functioning**: if the difference of temperature between the evaporator and the room probes is more than the value of the **Fct** parameter, the fans are switched on. With **Fct=0** the function is disabled.

3.3.2 Cyclical activation of the fans with compressor off.

When **FnC = c-n** or **c-Y** (fans in parallel to the compressor), by means of the **Fon** and **FoF** parameters the fans can carry out on and off cycles even if the compressor is switched off. When the compressor is stopped the fans go on working for the **Fon** time. With **Fon =0** the fans remain always off, when the compressor is off.

3.4 AUXILIARY RELAY CONFIGURATION - TERM.3-5, PAR. OA3

The functioning of the auxiliary relay (terminals. 3-5) can be set by the **oA3** parameter, according to the kind of application. In the following paragraph the possible setting:

3.4.1 Light relay - oA3= Lig

With **oA3 = Lig**, the 3-5 relay is set as light. It is activated by key or when **i1F = dor**.

3.4.2 Alarm relay – oA3= AUS

There are 2 possibilities:

a. Activation via digital input (oA3= AUS, i1F or i2F = AUS)

With **oA3 = AUS** and **i2F** or **i1F = AUS** the relay 3-5 is activated via digital input and remains ON until the digital input is activated or is silenced by pressing any key.

b. Auxiliary thermostat (es. anti-sweat heaters)

Parameters involved:

- **ACH** Type of regulation: heating/cooling;
- **SAA** Set point auxiliary relay
- **SHY** Differential for auxiliary relay
- **ArP** Probe for auxiliary relay
- **Sdd** Auxiliary output off during defrost

By means of these 5 parameters the functioning of the auxiliary relay can be set.

NOTE: Set **oA3=AUS** and **ArP= nP** (no probe for auxiliary output).

In this case the relay 3-5 can be activated only by digital input with **i1F** or **i2F = AUS**.

3.4.3 On/off relay – oA3= onF

In this case the relay is activated when the controller is turned on and de-activated when the controller is in stand-by mode.

3.4.4 Neutral zone regulation

With **oA3 = db** the relay 3-5 can control a heater element to perform a neutral zone action.

oA3 out in = SET-HY

oA3 out out = SET

3.4.5 Alarm relay

With **oA3 = AL** the relay 3-5 operates as alarm relay. It is activated every time an alarm happens. Its status depends on the **tbA** parameter:

With "**tbA = y**", the relay is silenced by pressing any key.

With "**tbA = n**", the alarm relay remains on until the alarm condition recovers.

3.4.6 Night blind management during energy saving cycles

With **oA3 = HES**, the relay 3-5 operates to manage the night blind: the relay is energised when the energy saving cycle is activated, by digital input, frontal button or RTC (optional).

4. FRONT PANEL COMMANDS

4.1 XW60LR - STANDARD FRONTAL PANEL



4.2 XW60LR - STEEL FINISHING



4.3 XW60LRH





SET: To display target set point; in programming mode it selects a parameter or confirm an operation.





(DEF) To start a manual defrost

(UP): To see the max. stored temperature; in programming mode it browses the parameter codes or increases the displayed value.

(DOWN) To see the min stored temperature; in programming mode it browses the parameter codes or decreases the displayed value.











-  To switch the instrument off, if onF = oFF.
-  To switch the light, if oA3 = Lig.

KEY COMBINATIONS:

-  +  To lock & unlock the keyboard.
- SET** +  To enter in programming mode.
- SET** +  To return to the room temperature display.



4.4 USE OF LEDS

Each LED function is described in the following table.



| LED | MODE | FUNCTION |
|--|----------|---------------------------------------|
|  | ON | Compressor enabled |
|  | Flashing | Anti-short cycle delay enabled |
|  | ON | Defrost enabled |
|  | Flashing | Drip time in progress |
|  | ON | Fans enabled |
|  | Flashing | Fans delay after defrost in progress. |
|  | ON | An alarm is occurring |
|  | ON | Continuous cycle is running |
|  | ON | Energy saving enabled |
|  | ON | Light on |
| FLUX | ON | Auxiliary relay on |
| °C | ON | Measurement unit |
| °C | Flashing | Programming phase |

5. MAX & MIN TEMPERATURE MEMORIZATION

5.1 HOW TO SEE THE MIN TEMPERATURE

1. Press and release the  key.
2. The "Lo" message will be displayed followed by the minimum temperature recorded.
3. By pressing the  key again or by waiting 5s the normal display will be restored.

5.2 HOW TO SEE THE MAX TEMPERATURE

1. Press and release the  key.
2. The "Hi" message will be displayed followed by the maximum temperature recorded.
3. By pressing the  key again or by waiting 5s the normal display will be restored.

5.3 HOW TO RESET THE MAX AND MIN TEMPERATURE RECORDED

1. Hold press the SET key for more than 3s, while the max. or min temperature is displayed. (rSt message will be displayed)
2. To confirm the operation the "rSt" message starts blinking and the normal temperature will be displayed.

6. MAIN FUNCTIONS

6.1 TO SET THE CURRENT TIME AND DAY (ONLY FOR INSTRUMENTS WITH RTC)

When the instrument is switched on, it's necessary to program the time and day.



1. Enter the Pr1 programming menu, by pushing the SET +  keys for 3s.
2. The rtc parameter is displayed. Push the SET key to enter the real time clock menu.
3. The Hur (hour) parameter is displayed.
4. Push the SET and set current hour by the UP and Down keys, then push SET to confirm the value..
5. Repeat the same operations on the Min (minutes) and dAy (day) parameters.

To exit: Push SET+UP keys or wait for 15 sec without pushing any keys.

6.2 HOW TO SEE THE SET POINT

- SET** 
1. Push and immediately release the SET key: the display will show the Set point value;
 2. Push and immediately release the SET key or wait for 5 seconds to display the probe value again.

6.3 HOW TO CHANGE THE SET POINT

1. Push the SET key for more than 2 seconds to change the Set point value;
2. The value of the set point will be displayed and the "°C" LED starts blinking;
3. To change the Set value push the  or  arrows within 10s.
4. To memorise the new set point value push the SET key again or wait 10s.

6.4 HOW TO START A MANUAL DEFROST

-  Push the DEF key for more than 2 seconds and a manual defrost will start.

6.5 HOW TO CHANGE A PARAMETER VALUE

To change the parameter's value operate as follows:





1. Enter the Programming mode by pressing the SET +  keys for 3s (the "°C" LED starts blinking).
2. Select the required parameter. Press the "SET" key to display its value

3. Use "UP" or "DOWN" to change its value.
 4. Press "SET" to store the new value and move to the following parameter.
- To exit: Press SET + UP or wait 15s without pressing a key.
NOTE: the set value is stored even when the procedure is exited by waiting the time-out to expire.

6.6 THE HIDDEN MENU

The hidden menu Includes all the parameters of the instrument.

6.6.1 HOW TO ENTER THE HIDDEN MENU

1. Enter the Programming mode by pressing the Set +  keys for 3s (the "°C" or "°F" LED starts blinking).
 2. Released the keys, then push again the Set+  keys for more than 7s. The Pr2 label will be displayed immediately followed from the HY parameter.
- NOW YOU ARE IN THE HIDDEN MENU.**
3. Select the required parameter.
 4. Press the "SET" key to display its value
 5. Use  or  to change its value.
 6. Press "SET" to store the new value and move to the following parameter.

To exit: Press SET +  or wait 15s without pressing a key.

NOTE1: if none parameter is present in Pr1, after 3s the "noP" message is displayed. Keep the keys pushed till the Pr2 message is displayed.

NOTE2: the set value is stored even when the procedure is exited by waiting the time-out to expire.

6.6.2 HOW TO MOVE A PARAMETER FROM THE HIDDEN MENU TO THE FIRST LEVEL AND VICEVERSA.



Each parameter present in the HIDDEN MENU can be removed or put into "THE FIRST LEVEL" (user level) by pressing "SET + ".

In HIDDEN MENU when a parameter is present in First Level the decimal point is on.



6.7 HOW TO LOCK THE KEYBOARD

1. Keep pressed for more than 3 s the UP + DOWN keys.
2. The "POF" message will be displayed and the keyboard will be locked. At this point it will be possible only to see the set point or the MAX o Min temperature stored
3. If a key is pressed more than 3s the "POF" message will be displayed.

6.8 TO UNLOCK THE KEYBOARD

Keep pressed together for more than 3s the  and  keys, till the "Pon" message will be displayed.

6.9 THE CONTINUOUS CYCLE

When defrost is **not** in progress, it can be activated by holding the "" key pressed for about 3 seconds. The compressor operates to maintain the "ccS" set point for the time set through the "CCt" parameter. The cycle can be terminated before the end of the set time using the same activation key "" for 3 seconds.

6.10 THE ON/OFF FUNCTION

 With "onF = oFF", pushing the ON/OFF key, the instrument is switched off. The "OFF" message is displayed. In this configuration, the regulation is disabled.
To switch the instrument on, push again the ON/OFF key.

WARNING: Loads connected to the normally closed contacts of the relays are always supplied and under voltage, even if the instrument is in stand by mode.

7. PARAMETERS

rtc Real time clock menu (only for controller with RTC): to set the time and date and defrost start time.

REGULATION

Hy Differential: (0,1 ÷ 25,5°C / 1÷255 °F) Intervention differential for set point. Compressor Cut IN is Set Point + differential (Hy). Compressor Cut OUT is when the temperature reaches the set point.

LS Minimum set point: (-50°C+SET/-58°F+SET); Sets the minimum value for the set point.

US Maximum set point: (SET+110°C/ SET+230°F). Set the maximum value for set point.

Ot Thermostat probe calibration: (-12.0÷12.0°C; -120÷120°F) allows to adjust possible offset of the thermostat probe.

P2P Evaporator probe presence: n= not present: the defrost stops by time; y= present: the defrost stops by temperature.

OE Evaporator probe calibration: (-12.0÷12.0°C; -120÷120°F). allows to adjust possible offset of the evaporator probe.

P3P Third probe presence (P3): n= not present; the terminals 13-14 operate as digital input.; y= present; the terminals 13-14 operate as third probe.

O3 Third probe calibration (P3): (-12.0÷12.0°C; -120÷120°F). allows to adjust possible offset of the third probe.

Ods Outputs activation delay at start up: (0÷255min) This function is enabled at the initial start up of the instrument and inhibits any output activation for the period of time set in the parameter.

AC Anti-short cycle delay: (0÷50 min) minimum interval between the compressor stop and the following restart.

rtr Percentage of the second and first probe for regulation (0÷100; 100 = P1, 0 = P2): it allows to set the regulation according to the percentage of the first and second probe, as for the following formula (rtr(P1-P2)/100 + P2).

CCt Compressor ON time during continuous cycle: (0.0÷24.0h; res. 10min) Allows to set the length of the continuous cycle: compressor stays on without interruption for the CCt time. Can be used, for instance, when the room is filled with new products.

CCS Set point for continuous cycle: (-50÷150°C) it sets the set point used during the continuous cycle.

CO n Compressor ON time with faulty probe: (0÷255 min) time during which the compressor is active in case of faulty thermostat probe. With CO n=0 compressor is always OFF.

COF Compressor OFF time with faulty probe: (0÷255 min) time during which the compressor is OFF in case of faulty thermostat probe. With COF=0 compressor is always active.

DISPLAY

- CF Temperature measurement unit:** °C=Celsius; °F=Fahrenheit. WARNING: When the measurement unit is changed the SET point and the values of the parameters Hy, LS, US, OT, ALU and ALL have to be checked and modified if necessary.
- rES Resolution (for °C):** (in = 1°C; dE = 0.1 °C) allows decimal point display.
- Lod Instrument display:** (P1; P2, P3, P4, SET, dtr); it selects which probe is displayed by the instrument: P1 = Thermostat probe; P2 = Evaporator probe; P3 = Third probe(only for model with this option enabled); P4 = NOT SET IT, SET = set point; dtr = percentage of visualization.
- rEd X-REP display (optional):** (P1; P2, P3, P4, SET, dtr); it selects which probe is displayed by X-REP: P1 = Thermostat probe; P2 = Evaporator probe; P3 = Third probe(only for model with this option enabled); P4 = NOT SET IT, SET = set point; dtr = percentage of visualization.
- dLy Display delay:** (0 ÷20.0m; resul. 10s) when the temperature increases, the display is updated of 1 °C/1°F after this time.
- dtr Percentage of the second and first probe for visualization when Lod = dtr (0÷100; 100 = P1, 0 = P2):** if Lod = dtr it allows to set the visualization according to the percentage of the first and second probe, as for the following formula $(dtr(P1-P2)/100 + P2)$.

DEFROST

- EdF Defrost mode (only for controller with RTC):**
rtc = Real Time Clock mode. Defrost time follows Ld1+Ld6 parameters on workdays and Sd1+Sd6 on holidays.
in = interval mode. The defrost starts when the time "ldf" is expired.
- tdF Defrost type:** EL = electrical heater; in = hot gas
- dFP Probe selection for defrost termination:** nP = no probe; P1 = thermostat probe; P2 = evaporator probe; P3 = configurable probe; P4 = NOT SET IT.
- dtE Defrost termination temperature:** (-50÷50 °C/ -58÷122°F) sets the temperature measured by the evaporator probe, which causes the end of defrost.
- ldF Interval between defrost cycles:** (0÷120h) Determines the time interval between the beginning of two defrost cycles.
- mdF (Maximum) length for defrost:** (0÷255min) When P2P = n, (not evaporator probe: timed defrost) it sets the defrost duration, when P2P = y (defrost end based on temperature) it sets the maximum length for defrost.
- dSd Start defrost delay:** (0÷59min) This is useful when different defrost start times are necessary to avoid overloading the plant.
- dFd Temperature displayed during defrost:** (rt = real temperature; it = temperature at defrost start; SET = set point; dEF = "dEF" label)
- dAd MAX display delay after defrost:** (0÷120min). Sets the maximum time between the end of defrost and the restarting of the real room temperature display.
- Fdt Drip time:** (0÷120 min) time interval between reaching defrost termination temperature and the restoring of the control's normal operation. This time allows the evaporator to eliminate water drops that might have formed due to defrost.
- dPo First defrost after start-up:** (y = immediately, n = after the ldF time)
- dAF Defrost delay after continuous cycle:** (0÷23.5h) time interval between the end of the fast freezing cycle and the following defrost related to it.

FANS

- FnC Fans operating mode:** C=n= runs with the compressor, OFF during defrost;
 o=n = continuous mode, OFF during defrost;
 C-Y = runs with the compressor, ON during defrost;
 o-Y = continuous mode, ON during defrost;
- Fnd Fans delay after defrost:** (0÷255min) Interval between end of defrost and evaporator fans start.
- Fct Temperature differential avoiding short cycles of fans** (0÷59°C; Fct=0 function disabled). If the difference of temperature between the evaporator and the room probes is more than the value of the Fct parameter, the fans are switched on.
- FSt Fans stop temperature:** (-50÷50°C/122°F) setting of temperature, detected by evaporator probe, above which fans are always OFF.
- Fon Fan ON time:** (0÷15 min) with Fnc = C, n or C, y, (fan activated in parallel with compressor), it sets the evaporator fan ON cycling time when the compressor is off. With Fon =0 and FoF ≠ 0 the fan are always off, with Fon=0 and FoF =0 the fan are always off.
- FoF Fan OFF time:** (0÷15 min) with Fnc = C, n or C, y, (fan activated in parallel with compressor), it sets the evaporator fan off cycling time when the compressor is off. With Fon =0 and FoF ≠ 0 the fan are always off, with Fon=0 and FoF =0 the fan are always off.
- FAP Probe selection for fan management:** nP = no probe; P1 = thermostat probe; P2 = evaporator probe; P3 = configurable probe; P4 = NOT SET IT.

AUXILIARY RELAY CONFIGURATION (terms. 3-5) – oA3 = AUS

- ACH Kind of regulation for auxiliary relay:** Ht = heating; CL = cooling
- SAA Set Point for auxiliary relay:** (-50.0÷110.0°C; -58÷230°F) it defines the room temperature set point to switch auxiliary relay.
- SHy Differential for auxiliary output:** (0,1 ÷ 25,5°C / 1÷255 °F) Intervention differential for auxiliary output set point.
 With ACH = cL AUX Cut in is SAA + SHy; . AUX Cut out is SAA
 With ACH = Ht AUX Cut in is SAA - SHy; . AUX Cut out is SAA
- ArP Probe selection for auxiliary:** nP = no probe, the auxiliary relay is switched only by button; P1 = Probe 1; P2 = Probe 2; P3 = Probe 3; P4 = NOT SET IT.
- Sdd Auxiliary relay off during defrost:** n = the auxiliary relay 3-5 operates during defrost.
 y = the auxiliary relay 3-5 is switched off during defrost.

ALARMS

- ALP Probe selection for alarm:** nP = no probe, the temperature alarms are disabled; P1 = Probe 1; P2 = Probe 2; P3 = Probe 3; P4 = NOT SET IT.
- ALC Temperature alarms configuration:** (Ab; rE)
 Ab= absolute temperature: alarm temperature is given by the ALL or ALU values. rE = temperature alarms are referred to the set point. Temperature alarm is enabled when the temperature exceeds the "SET+ALU" or "SET-ALL" values.
- ALU MAXIMUM temperature alarm:** (SET+110°C; SET+230°F) when this temperature is reached the alarm is enabled, after the "ALD" delay time.
- ALL Minimum temperature alarm:** (-50.0 ÷ SET °C; -58÷230°F) when this temperature is reached the alarm is enabled, after the "ALD" delay time.
- AFH Differential for temperature alarm/ fan recovery:** (0,1÷25,5°C; 1÷45°F) Intervention differential for recovery of temperature alarm. It's also used for the restart of the fan when the FSt temperature is reached
- ALd Temperature alarm delay:** (0÷255 min) time interval between the detection of an alarm condition and alarm signalling.

daO Exclusion of temperature alarm at start-up: (from 0.0 min to 23.5h) time interval between the detection of the temperature alarm condition after instrument power on and alarm signalling.

CONDENSER TEMPERATURE ALARM

- AP2 Probe selection for temperature alarm of condenser:** nP = no probe; P1 = thermostat probe; P2 = evaporator probe; P3 =configurable probe; P4 = NOT SET IT.
- AL2 Low temperature alarm of condenser:** (-55÷150°C) when this temperature is reached the LA2 alarm is signalled, possibly after the Ad2 delay.
- Au2 High temperature alarm of condenser:** (-55÷150°C) when this temperature is reached the HA2 alarm is signalled, possibly after the Ad2 delay.
- AH2 Differential for temperature condenser alarm recovery:** (0,1÷25,5°C; 1÷45°F)
- Ad2 Condenser temperature alarm delay:** (0÷255 min) time interval between the detection of the condenser alarm condition and alarm signalling.
- da2 Condenser temperature alarm exclusion at start up:** (from 0.0 min to 23.5h, res. 10min)
- bLL Compressor off with low temperature alarm of condenser:** n = no: compressor keeps on working; Y = yes, compressor is switched off till the alarm is present, in any case regulation restarts after AC time at minimum.
- AC2 Compressor off with high temperature alarm of condenser:** n = no: compressor keeps on working; Y = yes, compressor is switched off till the alarm is present, in any case regulation restarts after AC time at minimum.

AUXILIARY RELAY

- tbA Alarm relay silencing (with oA3 =ALR):**
 n= silencing disabled: alarm relay stays on till alarm condition lasts,
 y =silencing enabled: alarm relay is switched OFF by pressing a key during an alarm
- oA3 Fourth relay configuration (3-5):** dEF, FAn: do not select it! AL: alarm; Lig: light; AuS: Auxiliary relay; onF: always on with instrument on; db= neutral zone; cP2 = second compressor; dF2: do not select it!; HES: night blind.
- AoP Alarm relay polarity:** it set if the alarm relay is open or closed when an alarm happens. CL= terminals 1-4 closed during an alarm; oP = terminals 1-4 open during an alarm

DIGITAL INPUTS

- i1P Digital input 1 polarity (13-14):** oP: the digital input is activated by opening the contact; CL: the digital input is activated by closing the contact.
- i1F Digital input 1 configuration (13-14):** EAL= external alarm: "EA" message is displayed; bAL= serious alarm "CA" message is displayed. PAL= pressure switch alarm, "CA" message is displayed; dor= door switch function; dEF= activation of a defrost cycle; AUS=not enabled; Htr= kind of action inversion (cooling – heating); FAn= not set it; ES= Energy saving; HdF = Holiday defrost (enable only with RTC); onF = to switch the controller off.
- did (0÷255 min) with i1F= EAL or i1F= bAL digital input alarm delay (13-14):** delay between the detection of the external alarm condition and its signalling.
 with i1F= dor: door open signalling delay
 with i1F= PAL: time for pressure switch function: time interval to calculate the number of the pressure switch activation.
- i2P 2nd digital input polarity (13-19):** oP: the digital input is activated by opening the contact; CL: the digital input is activated by closing the contact.
- i2F 2nd digital input configuration (13-19):** EAL= external alarm: "EA" message is displayed; bAL= serious alarm "CA" message is displayed. PAL= pressure switch alarm, "CA" message is displayed; dor= door switch function; dEF= activation of a defrost cycle; AUS=not enabled; Htr= kind of action inversion (cooling – heating); FAn= not set it; ES= Energy saving; HdF = Holiday defrost (enable only with RTC); onF = to switch the controller off.
- d2d (0÷255 min) with i2F= EAL or i2F= bAL 2nd digital input alarm delay (13-19):** delay between the detection of the external alarm condition and its signalling.
 with i2F= dor: door open signalling delay
 with i2F= PAL: time for pressure switch function: time interval to calculate the number of the pressure switch activation.
- nPS Pressure switch number:** (0 ÷15) Number of activation of the pressure switch, during the "did" interval, before signalling the alarm event (i2F= PAL).
 If the nPS activation in the did time is reached, switch off and on the instrument to restart normal regulation.
- odc Compressor and fan status when open door:** no = normal; Fan = Fan OFF; CPr = Compressor OFF; F, C = Compressor and fan OFF.
- rrd Outputs restart after doA alarm:** no= outputs not affected by the doA alarm; yES = outputs restart with the doA alarm.
- HES Temperature increase during the Energy Saving cycle:**
 (-30.0°C÷30.0°C) it sets the increasing value of the set point during the Energy Saving cycle.

TO SET CURRENT TIME AND WEEKLY HOLIDAYS (ONLY FOR MODELS WITH RTC)

- Hur Current hour** (0 ÷ 23 h)
- Min Current minute** (0 ÷ 59min)
- dAY Current day** (Sun ÷ SA)
- Hd1 First weekly holiday** (Sun ÷ nu) Set the first day of the week which follows the holiday times.
- Hd2 Second weekly holiday** (Sun ÷ nu) Set the second day of the week which follows the holiday times.
- N.B.** Hd1,Hd2 can be set also as "nu" value (Not Used).

TO SET ENERGY SAVING TIMES (ONLY FOR MODELS WITH RTC)

- ILE Energy Saving cycle start during workdays:** (0 ÷ 23h 50 min.) During the Energy Saving cycle the set point is increased by the value in HES so that the operation set point is SET + HES.
- dLE Energy Saving cycle length during workdays:** (0 ÷ 24h 00 min.) Sets the duration of the Energy Saving cycle on workdays.
- ISE Energy Saving cycle start on holidays.** (0 ÷ 23h 50 min.)
- dSE Energy Saving cycle length on holidays** (0 ÷ 24h 00 min.)

TO SET DEFROST TIMES (ONLY FOR MODELS WITH RTC)

- Ld1+Ld6 Workday defrost start** (0 ÷ 23h 50 min.) These parameters set the beginning of the 6 programmable defrost cycles during workdays. Ex. When Ld2 = 12.4 the second defrost starts at 12.40 during workdays.
- Sd1+Sd6 Holiday defrost start** (0 ÷ 23h 50 min.) These parameters set the beginning of the 6 programmable defrost cycles on holidays. Ex. When Sd2 = 3.4 the second defrost starts at 3.40 on holidays.
- N.B.** .To disable a defrost cycle set it to "nu"(not used). Ex. If Ld6=nu ; the sixth defrost cycle is disabled

OTHER

Adr Serial address (1÷244): Identifies the instrument address when connected to a ModBUS compatible monitoring system.

PbC Type of probe: it allows to set the kind of probe used by the instrument: **PbC** = PBC probe, **ntc** = NTC probe.

onF on/off key enabling: **nu** = disabled; **oFF** = enabled; **ES** = not set it.

dP1 Thermostat probe display

dP2 Evaporator probe display

dP3 Third probe display- *optional*.

rSE Real set point: it shows the set point used during the energy saving cycle or during the continuous cycle.

rEL Software release for internal use.

Ptb Parameter table code: readable only.

8. DIGITAL INPUT

The first digital input is enabled with P3P = n.
With P3P = n and i1F = i2F the second digital input is disabled
The free voltage digital inputs are programmable by the "i1F" and i2F parameters.

8.1 GENERIC ALARM (i1F or i2F = EAL)

As soon as the digital input is activated the unit will wait for "did" time delay before signalling the "EAL" alarm message. The outputs status don't change. The alarm stops just after the digital input is de-activated.

8.2 SERIOUS ALARM MODE (i1F or i2F = bAL)

When the digital input is activated, the unit will wait for "did" delay before signalling the "CA" alarm message. The relay outputs are switched OFF. The alarm will stop as soon as the digital input is de-activated.

8.3 PRESSURE SWITCH (i1F or i2F = PAL)

If during the interval time set by "did" parameter, the pressure switch has reached the number of activation of the "nPS" parameter, the "CA" pressure alarm message will be displayed. The compressor and the regulation are stopped. When the digital input is ON the compressor is always OFF. If the nPS activation in the did time is reached, switch off and on the instrument to restart normal regulation.

8.4 DOOR SWITCH INPUT (i1F or i2F = dor)

It signals the door status and the corresponding relay output status through the "odc" parameter: **no** = normal (any change); **Fan** = Fan OFF; **CPr** = Compressor OFF; **F_C** = Compressor and fan OFF.
Since the door is opened, after the delay time set through parameter "did", the door alarm is enabled, the display shows the message "dA" and the regulation restarts is **rtr = yES**. The alarm stops as soon as the external digital input is disabled again. With the door open, the high and low temperature alarms are disabled.

8.5 START DEFROST (i1F or i2F = dEF)

It starts a defrost if there are the right conditions. After the defrost is finished, the normal regulation will restart only if the digital input is disabled otherwise the instrument will wait until the "MdF" safety time is expired.

8.6 SWITCH THE AUXILIARY RELAY (i1F or i2F = AUS)

With oA3 = AUS the digital input switched the status of the auxiliary relay

8.7 ENERGY SAVING (i1F or i2F = ES)

The Energy Saving function allows to change the set point value as the result of the SET+ HES (parameter) sum. This function is enabled until the digital input is activated.

8.8 HOLIDAY DEFROST (i1F or i2F = HDF) – ONLY FOR MODELS WITH RTC

This function enabled the holiday defrost setting.

8.9 ON OFF FUNCTION (i1F or i2F = onF)

To switch the controller on and off.

8.10 DIGITAL INPUTS POLARITY

The digital input polarity depends on the "i1P" parameter.
i1P or i2P = CL: the input is activated by closing the contact.
i1P or i2P = OP: the input is activated by opening the contact

9. TTL SERIAL LINE – FOR MONITORING SYSTEMS

The TTL serial line, available through the HOT KEY connector, allows by means of the external TTLRS485 converter, XJ485-CX, to connect the instrument to a monitoring system ModBUS-RTU compatible such as the X-WEB500/3000/300.

10. X-REP OUTPUT – OPTIONAL

As optional, an X-REP can be connected to the instrument, through the HOY KEY connector. The X-REP output EXCLUDES the serial connection.



To connect the X-REP to the instrument the following connectors must be used CAB-51F(1m), CAB-52F(2m), CAB-55F(5m),

11. INSTALLATION AND MOUNTING

The controller shall be mounted on vertical panel, in a 150x31 mm hole, and fixed using two screws Ø 3 x 2mm (only for XW60LR).
XW60LR: to obtain an IP65 protection grade use the front panel rubber gasket (mod. RG-L). The temperature range allowed for correct operation is 0 - 60 °C. Avoid places subject to strong vibrations, corrosive gases, excessive dirt or humidity. The same recommendations apply to probes. Let the air circulate by the cooling holes.

11.1 CUT OUT

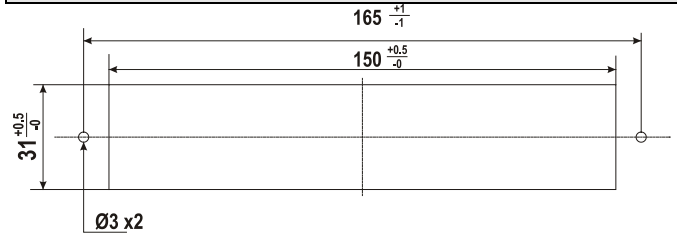

XW60LRH: the holes are not required

11.2 STEEL FINISHING MOUNTING

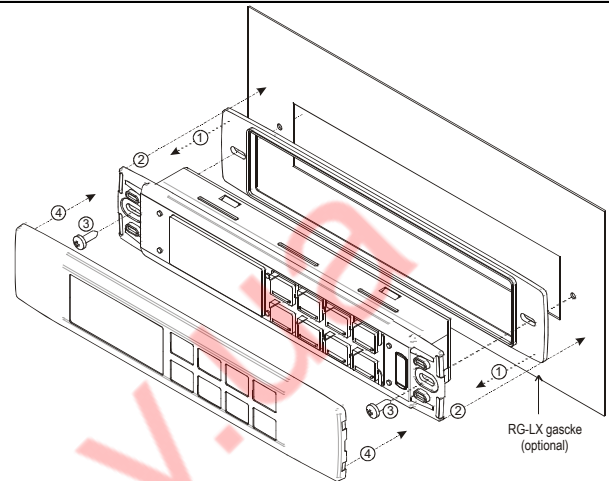

12. ELECTRICAL CONNECTIONS

The instruments are provided with screw terminal block to connect cables with a cross section up to 2,5 mm² for the digital and analogue inputs. Relays and power supply have a Faston connection (6,3mm). Heat-resistant cables have to be used. Before connecting cables make sure the power supply complies with the instrument's requirements. Separate the probe cables from the power supply cables, from the outputs and the power connections. Do not exceed the maximum current allowed on each relay, in case of heavier loads use a suitable external relay.
N.B. Maximum current allowed for all the loads is 20A.

12.1 PROBE CONNECTION

The probes shall be mounted with the bulb upwards to prevent damages due to casual liquid infiltration. It is recommended to place the thermostat probe away from air streams to correctly measure the average room temperature. Place the defrost termination probe among the evaporator fins in the coldest place, where most ice is formed, far from heaters or from the warmest place during defrost, to prevent premature defrost termination.

13. HOW TO USE THE HOT KEY

13.1 HOW TO PROGRAM A HOT KEY FROM THE INSTRUMENT (UPLOAD)

1. Program one controller with the front keypad.
2. When the controller is ON, insert the "Hot key" and push ▲ key; the "uPL" message appears followed a by flashing "End"
3. Push "SET" key and the End will stop flashing.
4. Turn OFF the instrument remove the "Hot Key", then turn it ON again.

NOTE: the "Err" message is displayed for failed programming. In this case push again ▲ key if you want to restart the upload again or remove the "Hot key" to abort the operation.

13.2 HOW TO PROGRAM AN INSTRUMENT USING A HOT KEY (DOWNLOAD)

1. Turn OFF the instrument.
2. Insert a programmed "Hot Key" into the 5 PIN receptacle and then turn the Controller ON.
3. Automatically the parameter list of the "Hot Key" is downloaded into the Controller memory, the "doL" message is blinking followed a by flashing "End".
4. After 10 seconds the instrument will restart working with the new parameters.
5. Remove the "Hot Key".

NOTE: the message "Err" is displayed for failed programming. In this case turn the unit off and then on if you want to restart the download again or remove the "Hot key" to abort the operation.

14. ALARM SIGNALS

| Message | Cause | Outputs |
|---------|----------------------------|--|
| "P1" | Room probe failure | Compressor output acc. to par. "Con" and "COF" |
| "P2" | Second probe failure | Defrost end is timed |
| "P3" | Third probe failure | Outputs unchanged |
| "HA" | Maximum temperature alarm | Outputs unchanged. |
| "LA" | Minimum temperature alarm | Outputs unchanged. |
| "HA2" | Condenser high temperature | It depends on the "Ac2" parameter |
| "LA2" | Condenser low temperature | It depends on the "bLL" parameter |
| "dA" | Door open | Compressor and fans restarts |
| "EA" | External alarm | Output unchanged. |

| Message | Cause | Outputs |
|---------|----------------------------------|--|
| "CA" | Serious external alarm (i1F=bAL) | All outputs OFF. |
| "rtc" | Real time clock alarm | Alarm output ON; Other outputs unchanged; Defrosts according to par. "IdF" Set real time clock has to be set |
| rtF | Real time clock board failure | Alarm output ON; Other outputs unchanged; Defrosts according to par. "IdF" Contact the service |

14.1 ALARM RECOVERY

Probe alarms "P1", "P2", "P3" start some seconds after the fault in the related probe; they automatically stop some seconds after the probe restarts normal operation. Check connections before replacing the probe.

Temperature alarms "HA", "LA" "HA2" and "LA2" automatically stop as soon as the temperature returns to normal values.

Alarms "EA" and "CA" (with i1F=bAL) recover as soon as the digital input is disabled.

Real time clock alarm rTc, it stops as soon as the correct hour and day are set.

Real time clock alarm rTf, the clock board has to be replaced. Contact the service.

14.2 OTHER MESSAGES

| | |
|-----|--|
| Pon | Keyboard unlocked. |
| PoF | Keyboard locked |
| noP | In programming mode: none parameter is present in Pr1 On the display or in dP2, dP3, dP4: the selected probe is nor enabled |

15. TECHNICAL DATA

Housing: self extinguishing ABS.

Case: facia 38x185 mm; depth 40mm

Mounting : panel mounting in a 150x31 mm panel cut-out with

Only for XW60LR: two screws. \varnothing 3x2mm, distance between holes 165mm

Protection: IP20;

Frontal protection: IP65 Only for XW60LR with frontal gasket mod RG-L or RG-LX.

Connections: Screw terminal block \leq 1 mm² heat-resistant wiring for very low voltage, Screw terminal block \leq 2,5 mm² heat-resistant wiring for low voltage (110 or 230Vac).

Power supply: 230Vac or . 110Vac \pm 10%, 50/60Hz.

Power absorption: 7VA max.

Display: 3 digits, red LED, 14,2 mm high.

Inputs: Up to 4 NTC or PTC probes.

Digital inputs: free of voltage

Relay outputs: **Total current on loads MAX. 20A**

compressor: relay SPST 20(8) A, 250Vac

light: relay SPST 5A, 250Vac

fans: relay SPST 5 A, 250Vac

defrost: relay SPST 8(3) A, 250Vac

Other output : buzzer (optional)

Serial output : TTL as alternate to X-REP output

X-REP output : optional as alternate to TTL serial output

Communication protocol: Modbus - RTU

Data storing: on the non-volatile memory (EEPROM).

Internal clock back-up: 24 hours (only for model with RTC)

Kind of action: 1B; Pollution grade: normal; Software class: A.;

Over voltage Category: II

Operating temperature: 0+60 °C; Storage temperature: -30+85 °C.

Relative humidity: 20+85% (no condensing)

Measuring and regulation range: NTC probe: -40+110°C (-40+230°F);

PTC probe: -50+150°C (-58+302°F)

Resolution: 0,1 °C or 1 °F (selectable); Accuracy (ambient temp. 25°C): \pm 0,7 °C \pm 1 digit

16. CONNECTIONS

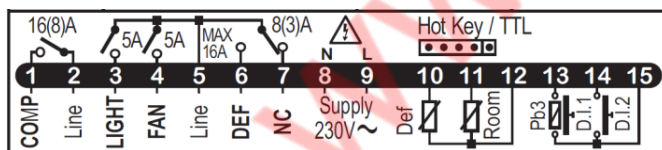

Supply: 120Vac: connect to terminals 8-9.

NOTE: on models with X-REP option, connect the X-REP to the HOT KEY receptacle

17. DEFAULT SETTING VALUES

| Label | Name | Range | °C/°F | Level |
|-------|---------------------------------------|----------------------------|-------|-------|
| Set | Set point | LS - US | -5.0 | --- |
| rtc* | Real time clock menu | | - | Pr1 |
| Hy | Differential | (0,1°C + 25,5°C) | 2.0 | Pr1 |
| LS | Minimum set point | (-55,0°C \pm SET) | -50.0 | Pr2 |
| US | Maximum set point | (SET + 150,0°C) | 110 | Pr2 |
| Ot | P1 probe calibration | (-12,0°C \pm 12,0°C) | 0.0 | Pr1 |
| P2P | P2 probe presence | n - Y | Y | Pr1 |
| OE | P2 probe calibration | (-12,0°C \pm 12,0°C) | 0.0 | Pr2 |
| P3P | P3 probe presence | n - Y | n | Pr2 |
| O3 | P3 probe calibration | (-12,0°C \pm 12,0°C) | 0 | Pr2 |
| OdS | Outputs delay at start up | 0 \pm 255 (min.) | 0 | Pr2 |
| AC | Anti-short cycle delay | 0 \pm 50 (min.) | 1 | Pr1 |
| AC1 | Second compressor start delay | 0 \pm 255 (sec.) | 5 | Pr2 |
| rtr | P1-P2 percentage for regulation | 0 \pm 100 (100=P1, 0=P2) | 100 | Pr2 |
| CCt | Continuous cycle duration | 0 \pm 24H0(144) | 0.0 | Pr2 |
| CCS | Set point for continuous cycle | (-55,0°C + 150,0°C) | -5 | Pr2 |
| COn | Compressor ON time with faulty probe | 0 \pm 255 (min.) | 15 | Pr2 |
| COF | Compressor OFF time with faulty probe | 0 \pm 255 (min.) | 30 | Pr2 |

| Label | Name | Range | °C/°F | Level |
|-------|---|--|-------|-------|
| CF | Temperature measurement unit | °C - °F | °C | Pr2 |
| rES | Resolution | dE - in | dE | Pr1 |
| Lod | Probe displayed | P1 - P2 - P3 - P4 - SET - dtr | P1 | Pr2 |
| rEd2 | X-REP display | P1 - P2 - P3 - P4 - SET - dtr | P1 | Pr2 |
| dLy | Display temperature delay | 0 \pm 20.0min (ris. 10 sec.) | 0.0 | Pr2 |
| dtr | P1-P2 percentage for display | 1 \pm 99 | 50 | Pr2 |
| EdF* | Kind of interval for defrost | rtc=in | in | Pr2 |
| tdF | Defrost type | EL - in | EL | Pr1 |
| tdFP | Probe selection for defrost termination | nP - P1 - P2 - P3 - P4 | P2 | Pr2 |
| dtE | Defrost termination temperature | (-55,0°C \pm 50,0°C) | 8.0 | Pr1 |
| IdF | Interval between defrost cycles | 0 \pm 120 (ore) | 6 | Pr1 |
| MdF | (Maximum) length for defrost | 0 \pm 255 (min.) | 30 | Pr1 |
| dSd | Start defrost delay | 0 \pm 255 (min.) | 0 | Pr2 |
| dFd | Displaying during defrost | rt - it - SET - DEF | it | Pr2 |
| dAd | MAX display delay after defrost | 0 \pm 255 (min.) | 30 | Pr2 |
| Fdt | Draining time | 0 \pm 255 (min.) | 0 | Pr2 |
| dPo | First defrost after start-up | n - Y | n | Pr2 |
| dAF | Defrost delay after fast freezing | 0 \pm 24.0h; ris. 10min | 0.0 | Pr2 |
| Fnc | Fan operating mode | C n - O n - C Y - O Y | o-n | Pr1 |
| Fnd | Fan delay after defrost | 0 \pm 255 (min.) | 10 | Pr1 |
| Fct | Differential of temperature for forced activation of fans | (0°C \pm 50°C) | 10 | Pr2 |
| FSt | Fan stop temperature | (-55,0°C \pm 50,0°C) | 2 | Pr1 |
| Fon | Fan on time with compressor off | 0+15 (min.) | 0 | Pr2 |
| Fof | Fan off time with compressor off | 0+15 (min.) | 0 | Pr2 |
| FAP | Probe selection for fan management | nP - P1 - P2 - P3 - P4 | P2 | Pr2 |
| ACH | Kind of action for auxiliary relay | CL - Ht | cL | Pr2 |
| SAA | Set Point for auxiliary relay | (-55,0°C \pm 150,0°C) | 0,0 | Pr2 |
| SHy | Differential for auxiliary relay | (0,1°C \pm 25,5°C) | 2,0 | Pr2 |
| ArP | Probe selection for auxiliary relay | nP - P1 - P2 - P3 - P4 | nP | Pr2 |
| Sdd | Auxiliary relay operating during defrost | n - Y | n | Pr2 |
| ALP | Alarm probe selection | nP - P1 - P2 - P3 - P4 | P1 | Pr2 |
| ALc | Temperat. alarms configuration | rE - Ab | Ab | Pr2 |
| ALU | MAXIMUM temperature alarm | ALc=rE: 0.0+ 50.0°C ALc=Ab: ALL+150°C | 110,0 | Pr1 |
| ALL | Minimum temperature alarm | ALc = rE: 0.0+50.0°C; ALc=Ab: -55°C+ALU | -50,0 | Pr1 |
| AFH | Differential for temperat. alarm recovery | (0,1°C \pm 25,5°C) | 2,0 | Pr2 |
| ALd | Temperature alarm delay | 0 \pm 255 (min.) | 15 | Pr2 |
| dAO | Delay of temperature alarm at start up | 0 \pm 24.0 h ris. 10min | 1,3 | Pr2 |
| AP2 | Probe for temperat. alarm of condenser | nP - P1 - P2 - P3 - P4 | P4 | Pr2 |
| AL2 | Condenser for low temperat. alarm | (-55,0°C \pm 150,0°C) | -40 | Pr2 |
| AU2 | Condenser for high temperat. alarm | (-55,0°C \pm 150,0°C) | 110 | Pr2 |
| AH2 | Differ. for condenser temp. alar. recovery | (0,1°C \pm 25,5°C) | 5 | Pr2 |
| Ad2 | Condenser temperature alarm delay | 0 \pm 255 (min.) | 15 | Pr2 |
| dA2 | Delay of cond. temper. alarm at start up | 0 \pm 24H0(144) | 1,3 | Pr2 |
| bLL | Compr. off for condenser low temperature alarm | n - Y | n | Pr2 |
| AC2 | Compr. off for condenser high temperature alarm | n - Y | n | Pr2 |
| tbA | Alarm relay disabling | n - Y | y | Pr2 |
| oA3 | Third relay configuration | dEF - FAn - ALr - LiG - AUS - OnF - db - CP2 - dF2 - HES | Lig | Pr2 |
| AoP | Alarm relay polarity | OP - CL | cL | Pr2 |
| i1P | Digital input polarity | OP - CL | cL | Pr1 |
| i1F | Digital input 1 configuration | EAL - bAL - PAL - dor - dEF - AUS - Htr - FAn - ES-HdF - onF | dor | Pr1 |
| did | Digital input alarm delay | 0 \pm 255 (min.) | 15 | Pr1 |
| i2P | Digital input 2 polarity | OP - CL | cL | Pr2 |
| i2F | Digital input 2 configuration | EAL - bAL - PAL - dor - dEF - AUS - Htr - FAn - ES-HdF - onF | EAL | Pr2 |
| d2d | Digital input alarm delay | 0 \pm 255 (min.) | 5 | Pr2 |
| nPS | Number of activation of pressure switch | 0 \pm 15 | 15 | Pr2 |
| odc | Compress and fan status when open door | no - FAn - CPr - F-C | F-c | Pr2 |
| rrd | Regulation restart with door open alarm | n - Y | y | Pr2 |
| HES | Differential for Energy Saving | (-30°C \pm 30°C) | 0 | Pr2 |
| Hur* | Current hour | Read only | - | Pr1 |
| Min* | Current minute | Read only | - | Pr1 |
| dAY* | Current day | Read only | - | Pr1 |
| Hd1* | First weekly holiday | Sun + SAT - nu | nu | Pr1 |
| Hd2* | Second weekly holiday | Sun + SAT - nu | nu | Pr1 |
| ILE* | Energy Saving cycle start during workdays | 0 \pm 23h5 | 0.0 | Pr1 |
| dLE* | Energy Saving cycle length during workdays | 0 \pm 24h0 | 0 | Pr1 |
| ISE* | Energy Saving cycle start on holidays | 0 \pm 23h5 | 0.0 | Pr1 |
| dSE* | Energy Saving cycle length on holidays | 0 \pm 24h0 | 0 | Pr1 |
| Ld1* | 1 st workdays defrost start | 0 \pm 23H5; - nu | nu | Pr1 |
| Ld2* | 2 nd workdays defrost start | 0 \pm 23H5; - nu | nu | Pr1 |
| Ld3* | 3 rd workdays defrost start | 0 \pm 23H5; - nu | nu | Pr1 |
| Ld4* | 4 th workdays defrost start | 0 \pm 23H5; - nu | nu | Pr1 |
| Ld5* | 5 th workdays defrost start | 0 \pm 23H5; - nu | nu | Pr1 |
| Ld6* | 6 th workdays defrost start | 0 \pm 23H5; - nu | nu | Pr1 |
| Sd1* | 1 st holiday defrost start | 0 \pm 23H5; - nu | nu | Pr1 |
| Sd2* | 2 nd holiday defrost start | 0 \pm 23H5; - nu | nu | Pr1 |
| Sd3* | 3 rd holiday defrost start | 0 \pm 23H5; - nu | nu | Pr1 |
| Sd4* | 4 th holiday defrost start | 0 \pm 23H5; - nu | nu | Pr1 |

| Label | Name | Range | °C/°F | Level |
|-------|---------------------------------------|----------------|-------|-------|
| Sd5* | 5 th holiday defrost start | 0 ÷ 23H5; - nu | nu | Pr1 |
| Sd6* | 6 th holiday defrost start | 0 ÷ 23H5; - nu | nu | Pr1 |
| Adr | Serial address | 1 ÷ 247 | 1 | Pr2 |
| PbC | Kind of probe | PtC - ntC | ntc | Pr2 |
| onF | on/off key enabling | nu - OFF - ES | oFF | Pr2 |
| dP1 | Room probe display | Probe value | - | Pr2 |
| dP2 | Evaporator probe display | Probe value | - | Pr2 |
| dP3 | Third probe display | Probe value | - | Pr2 |
| rSE | Real set | Read only | - | Pr2 |
| rEL | Software release | Read only | 1.8 | Pr2 |
| Ptb | Map code | Read only | | Pr2 |

2 Only for model with X-REP output

* Only for model with real time clock

www.kiy-v.ua

Dixell



Dixell S.r.l. - Z.I. Via dell'Industria, 27 - 32010 Pieve d'Alpago (BL) ITALY
Tel. +39.0437.9833 r.a. - Fax +39.0437.989313 - EmersonClimate.com/Dixell - dixell@emerson.com