

SCHEDA INSTALLAZIONE

THRILL VORTEX S.B.I.

Special for Built In

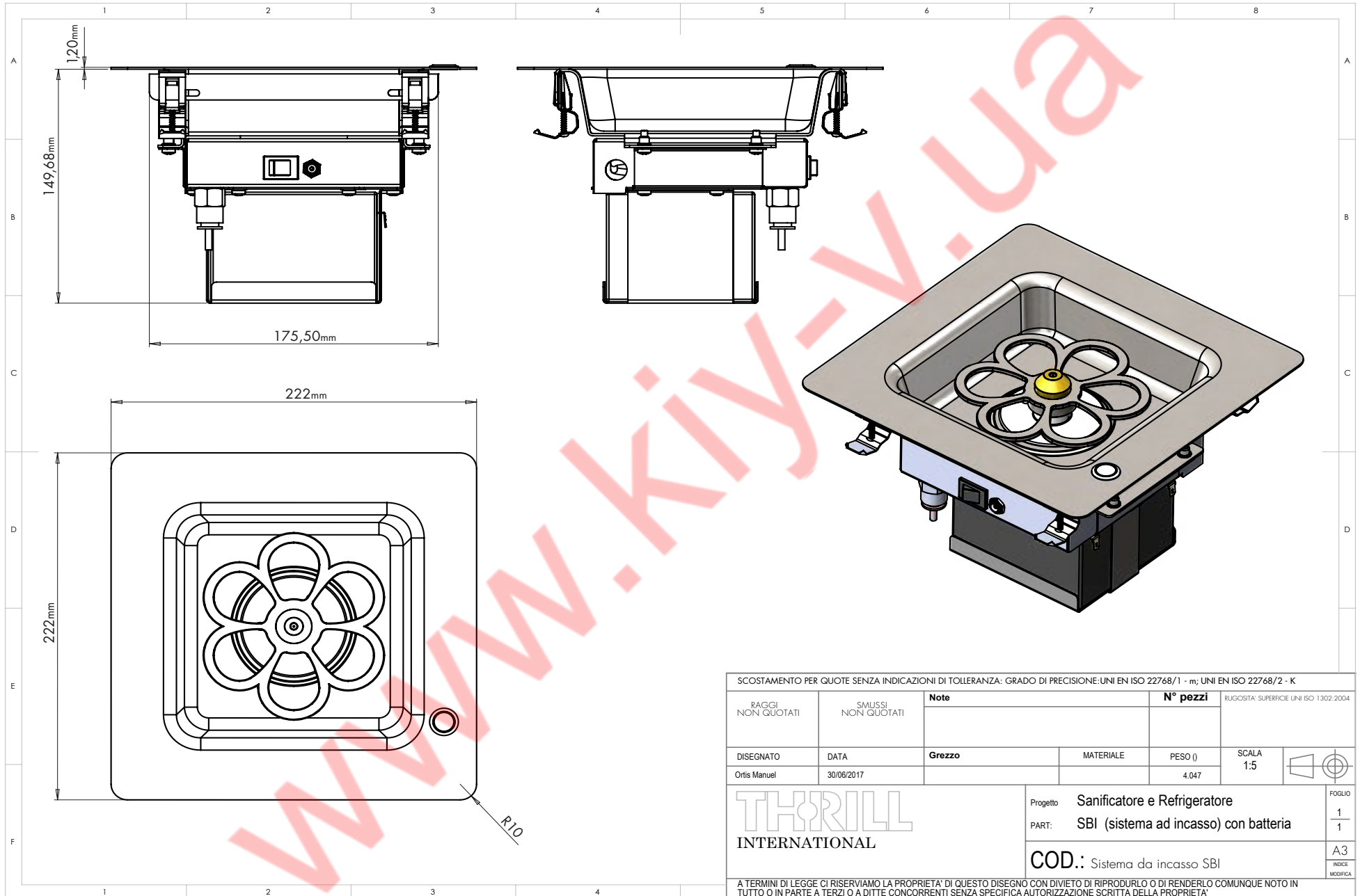



SCOSTAMENTO PER QUOTE SENZA INDICAZIONI DI TOLLERANZA: GRADO DI PRECISIONE: UNI EN ISO 22768/1 - m; UNI EN ISO 22768/2 - K					
RAGGI NON QUOTATI	SMUSSI NON QUOTATI	Note	N° pezzi	RUGOSITA' SUPERFICIE UNI ISO 1302:2004	
DISEGNATO	DATA	Grezzo	MATERIALE	PESO (g)	SCALA
Ortis Manuel	30/06/2017			4.047	1:5
		Progetto Sanificatore e Refrigeratore			FOGLIO 1/1 A3 INDICE MODIFICA
		PART: SBI (sistema ad incasso) con batteria			
		COD.: Sistema da incasso SBI			
A TERMINI DI LEGGE CI RISERVIAMO LA PROPRIETA' DI QUESTO DISEGNO CON DIVIETO DI RIPRODURLO O DI RENDERLO COMUNQUE NOTO IN TUTTO O IN PARTE A TERZI O A DITTE CONCORRENTI SENZA SPECIFICA AUTORIZZAZIONE SCRITTA DELLA PROPRIETA'					



Ingombri minimi impiegati dal sistema

System with minimal space requirements

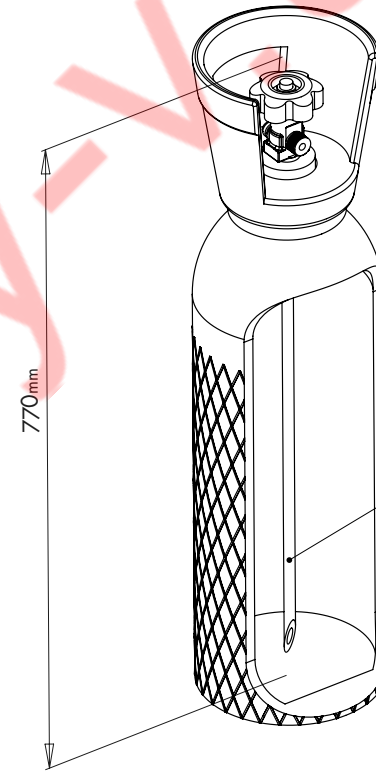
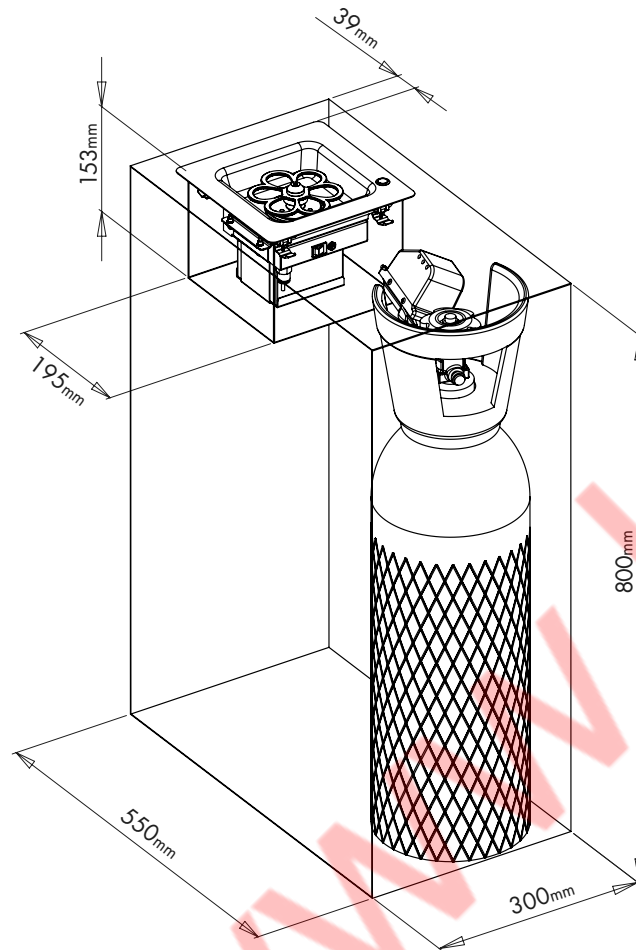

LA BOMBOLA DI CO₂ USATA
DEVE ESSERE DEL TIPO
DOTATO DI TUBO PESCANTE.

CO₂ CYLINDER WITH SYPHON
TUBE IS REQUIRED.

Misure e caratteristiche medie di una bombola di CO₂ da 10Kg

Average measurements and characteristics of a 10Kg CO₂ cylinder



Sistema di funzionamento gancio a doppia asola

EN - Fastening system with double buttonhole

FR - Système de montage des pattes de fixation à double oese

DE - Befestigungssystem der Krallen mit doppelter Oese

SP - Sistema de fijación de grapas a doble ojal

IT

Raccomandazioni per l'installatore:

1. Non saldare Vortex SBI al banco/piano d'appoggio.

L'eventuale saldatura della vaschetta superiore in inox ridurrà la possibilità di interventi di manutenzione. In caso di saldatura, il prodotto THRILL verrà considerato alterato dalle sue condizioni originali, compromettendo la validità della garanzia del costruttore.

2. Utilizzare l'apposito kit di ancoraggio THRILL.

L'ancoraggio del prodotto al banco/piano deve essere effettuato preferibilmente utilizzando il Kit Rimovibile fornito in dotazione dal costruttore.

EN

Recommendations for the installation expert:

1. Do not weld the Vortex SBI to the counter-top.

Welding the inox upper tray to the table top/counter-top will irreparably hamper any practicability of maintenance interventions.

In case of welding, the THRILL product will be considered altered from its original manufacturing conditions, causing immediate nullification of warranty coverage.

2. Use THRILL fastening kit.

Fastening the product to the counter-top must be done exclusively by using the specific kit provided.

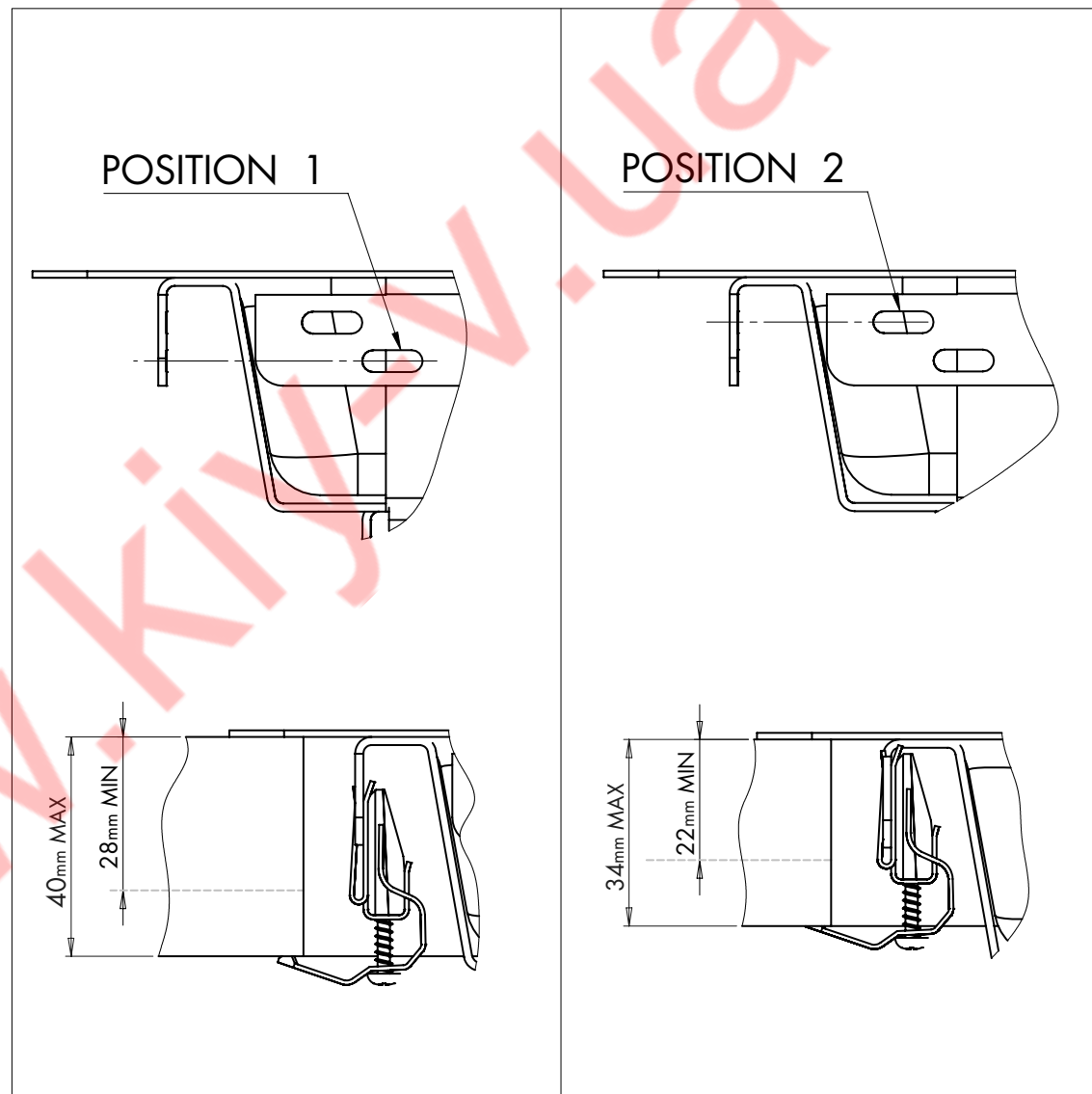



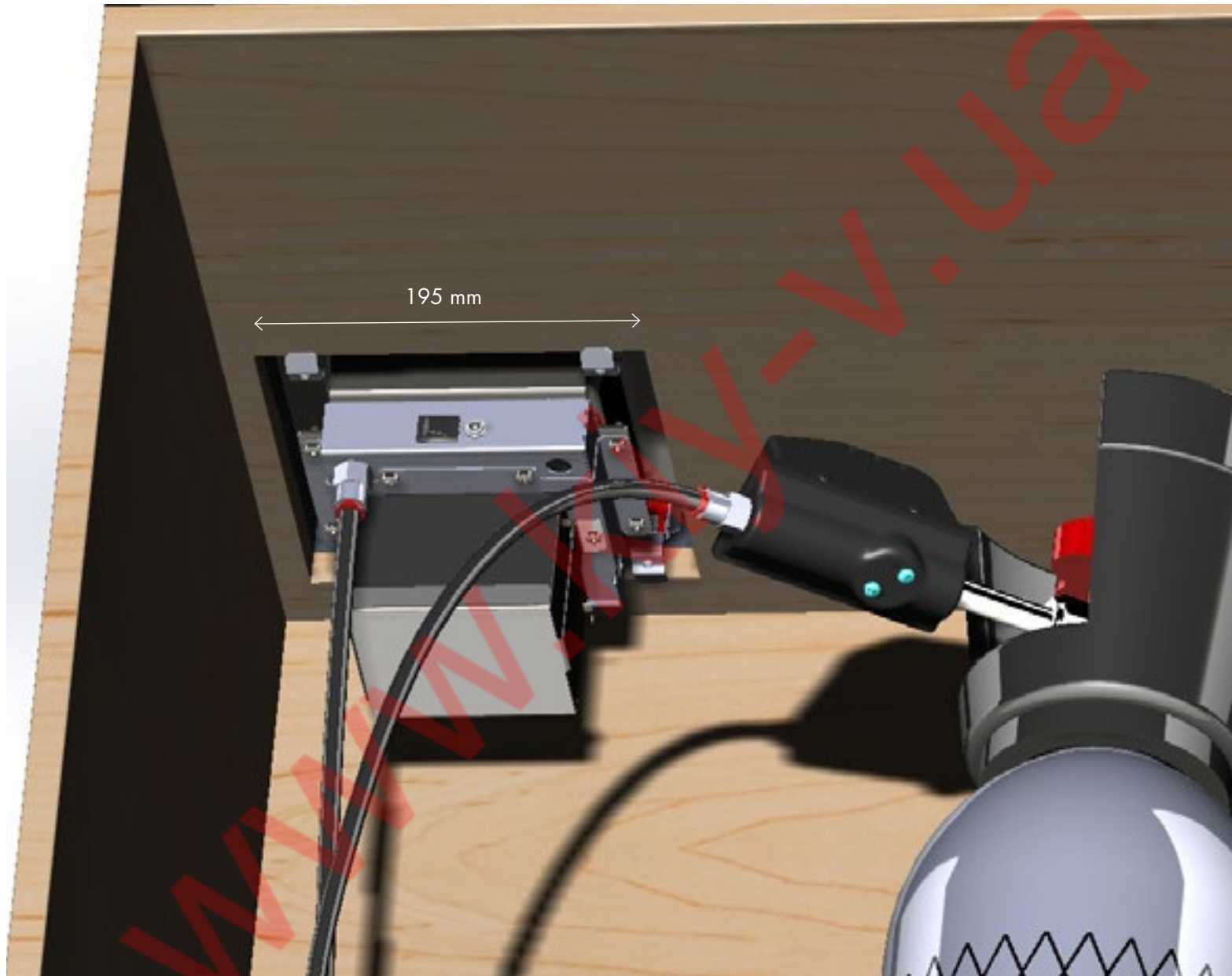

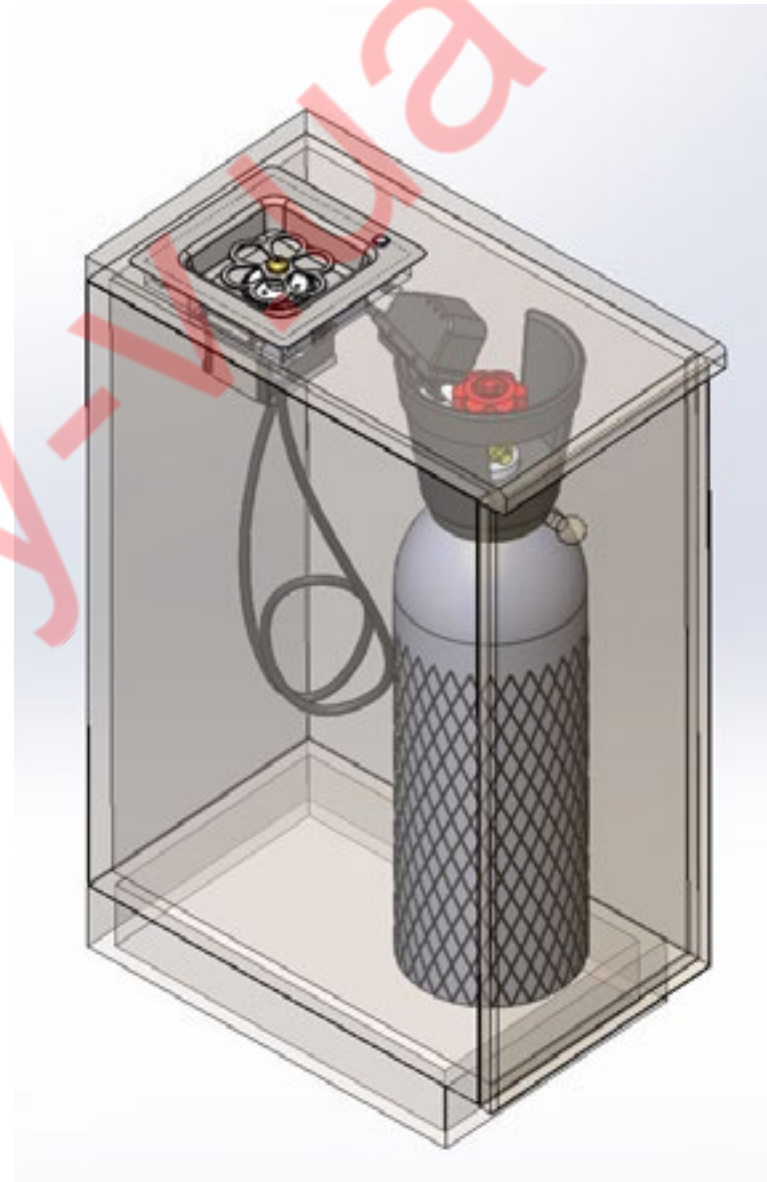
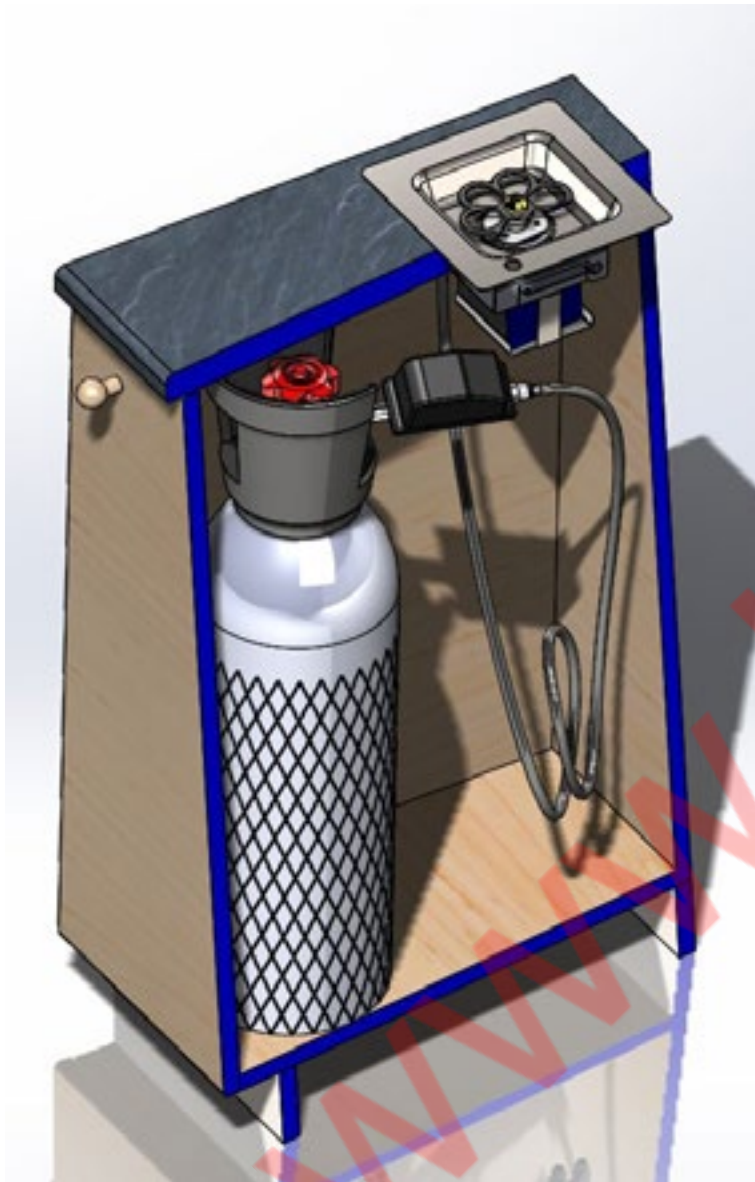

THRILL
INTERNATIONAL

via Ippolis, 101
Udine, Italy
+39 0432 582 374

www.thrillinternational.com